

**CATÁLOGO
GENERAL**



furio
suministros industriales

**- 2023 -
3ª Edición**

índice

Rodamientos SKF.....	13
Rótulas y soportes pie SKF	14
Rodamiento lineal y casquillos SKF.....	15
Instrumentos: montaje, desmontaje y grasas SKF.....	16
Alquiler de calentadores de inducción para rodamientos	17
Rodamientos FAG.....	18
Rodamientos INA	19
Rodamientos ISB.....	20
Patines y guías	
THK, HIWIN, SKF	21
TBK, IGUS, INA	22
THOMSON, NSK, REXROTH.....	23
PMI, IKO, NADELLA	24
Rodamientos y guías FARO y rodamientos y soportes antirretorno STIEBER	25
Retenes y juntas tóricas de nitrilo y viton	26
Cierres mecánicos	27
Correas y cordón termosoldable 4-BELT	28 y 29
Correa termosoldable	30
Utensilios para unir correas y neumático para unión OVERLAP	31
Correas industriales BANDO	32
Línea de producción cerámica BANDO.....	33 y 34
Correa a metros en PU BANDO	35, 36 y 37
Correa a metros en PU + NFT BANDO	38
Correa modular ACCU-LINK y crestada en caucho	39
Correa para línea de selección.....	40
Correa para línea de selección recubierta PU.....	41
Correa para salida de horno y correa para rectificadora.....	42
Transmisión: piños, taper, etc. BEA.....	43
Acoplamientos ALBERT, CIDEPA, BEA, GEAR.....	44
Acoplamientos SAMIFLEX, NIL-UNION, PAGUFLEX y KTR.....	45
Cadena robótica IGUS.....	46
Perfiles APM / Poligur.....	47
Vulcanizado de piezas en poliuretano	48
Discos de corte, desbarbar, discos lijas, etc. Abrasivos SAIT	49
Soportes antivibrantes / silentblocks MECANOCAUCHO.....	50
Tornillos pav / zinc / inox: chavetas, pies, bridas rápidas OPAC.....	51
Abrazaderas, segers, grilletes, cáncamos, etc. MIKALOR	52
Válvulas de esfera GENEBRE.....	53
Recambios, filtros, bombas y tubo para impresoras Inkjet	54
Bombas FLOJET, servilletas TORK y anticongelante orgánico QUIMICAR.....	55
Pies giratorios inox / zinc y fleje de acero	56
Equipos de lubricación MATO	57
Grasas, aceites, espráis técnicos, adhesivos y sellantes, higiene, otros KRAFFT.....	58 y 59
Multiusos WD40 y selladores, espumas y adhesivos SOUDAL.....	60
Cintas y adhesivos MIARCO.....	61
Productos químicos QUIMICAR	62
Limpieza industrial	63
Limpieza: cubos, fregona, recogedor, etc.....	64
Pilas DURACELL.....	65
Cúter, rasqueta y linternas	66
Productos de ordenación TAYG.....	67
Racores y accesorios, enchufes rápidos, cilindros y tubería NORDAIR	68
Válvulas, válvulas con actuador, manómetros y redes NORDAIR.....	69
Tubería industrial TECNIMAN	70 y 71
Racores rótula TECNIMAN.....	71
Racores Guillemin TECNIMAN.....	71
Racores Kamlock TECNIMAN	72

índice

Planchas TECNIMAN.....	72
Rulos abrasivos para desbarbar en seco.....	73
Tubo para forrar rodillos PVC + neopreno, PU, silicona.....	74 y 75
Boquillas soplado, accesorios y válvula contador aire.....	76
Green Blow FM.....	77
Herramientas BAHCO.....	78 - 82
GAYNER.....	83
Instrumentos de verificación y control KALKUM.....	84
Almacenaje ASLAK.....	85
Barreras de protección ASLAK.....	85
Equipamiento de taller ASLAK.....	85
Limpieza profesional ASLAK.....	86
Carretillas, mesas elevadoras y transpaletas ASLAK.....	87
Herramientas para metal ASLAK.....	88, 89 y 90
Herramientas de medición ASLAK.....	91
Herramientas para madera ASLAK.....	91
Herramientas de soldadura ASLAK.....	92
Herramientas de aire comprimido ASLAK.....	92
Ventiladores y calefactores ASLAK.....	92
Equipos de soldadura SOLTER.....	93
Soldadura: consumibles, antorchas y accesorios CROMAWELD.....	94
Herramienta de corte y accesorios TIVOLY.....	95
Herramienta eléctrica y baterías BOSCH.....	96
Herramienta neumática y taladros columna AIXIA y YAIM.....	97
Escaleras y andamios PLABELL.....	98
Sistemas para la aplicación de sellantes y adhesivos MELER.....	99
Imanes IMA.....	100
Cepillería industrial FECIN.....	101
Cepillos industriales para limpieza.....	102
Ruedas industriales TECNITEM.....	103
Ruedas temperaturas extremas TECNITEM.....	103
Rodillos transpaletas TECNITEM.....	103
Zapatos ROBUSTA.....	104 y 105
Guantes y ropa JUBA.....	106 y 107
Epis PERSONNA.....	108
Ventiladores SODECA.....	109
Bombas VENETO, SAER, SHURFLO, AIG y LORENTZ.....	110, 111 y 112
Motores eléctricos ALREN, SIEMENS, ABB, ELTE, SACCARDO y MINIMOTOR.....	113 y 114
Motores freno y embragues MGM y KEB.....	115
Reductores	
MOTOVARIO, MARTINENA y ROSSI.....	116
BONFIGLIOLI, CUÑAT y SITI.....	117
TIMSA y CIDIPA.....	118
TRAMEC, RALPE y NORD.....	119
BREVINI, PUJOL, GM y TRANSTECNO.....	120 y 121
Vibradores neumáticos y eléctricos OMB, URBAR y OLI.....	122
Freno-tambor neumático EATON.....	123
Máquina DUERRE y accesorios.....	124
Material horno UNIFRAX.....	125
Termocopias SETER.....	126
Uñas, muelles y rodamientos cerámicos para horno.....	127
Repuestos de rectificadora y pulidora TIENNEKAPPA.....	128 y 129
Correa Taracx para rectificadora GATES.....	130
Correa Fishbone PU para girador de rectificadora GATES.....	131
Mesas calibradoras TIENNEKAPPA.....	132
Green Tornado TIENNEKAPPA.....	133
Útiles diamantados / fickert SAID.....	134 y 135
Utensilios para máquina de corte: platos, canutos, presores, etc.....	136 y 137
Material atomizador de carburo de tungsteno, distribuidor, caracola, rondela, etc.....	138-147
Equipos de engrase para molinos continuos FLENCO.....	148

¿Quiénes somos?

Suministros Industriales Furio S.L. es una empresa dedicada a la comercialización de suministros para el sector cerámico e industrias satélites, cuyo servicio se dirige a empresas y profesionales tanto del ámbito nacional como internacional, destacando por una fuerte implantación en el área geográfica de Castellón.

Nuestra misión es procurar el mejor servicio a nuestros clientes. Para ello, contamos con una plantilla que acredita más de 25 años de experiencia en el sector cerámico.

Queremos que nuestra imagen sea la de una empresa de distribución especializada, seria y comprometida, basada en una cultura de esfuerzo

constante por mejorar, con el propósito de facilitar la gestión operativa de nuestros clientes.



Nuestros **objetivos** son:



Liderar el sector y buscar la implantación a nivel nacional e internacional.

Desarrollar un proyecto empresarial sólido, viable y duradero, aportando nuestra experiencia y profesionalidad.

Proporcionar rentabilidad a medio y largo plazo, y garantizar el desarrollo de nuestro proyecto, gracias a la implicación entre proveedor y cliente.

Ofrecer a nuestros clientes las soluciones necesarias en productos y servicios que contribuyan a satisfacer sus necesidades. Para lograrlo, disponemos de stock permanente en una amplia variedad de referencias activas, además de incorporar rápidamente nuevos productos según demanda.

Crear un clima de confianza entre nuestro equipo, así como con clientes y proveedores.

About us

Suministros Industriales Furio S.L. is a company dedicated to the commercialization of supplies for the industry in the ceramic sector and satellite industries, aimed at companies and professionals both nationally and internationally, stressing above all by a strong implantation in the geographic area of the province of Castellón.

Our staff possesses the experience accredited of 25 years in the ceramic sector trying to get a firm objective which is that to provide the best service to our customers.



We want that our image is that of a serious company, distribution company specialized, based on a culture of constant improvement effort to facilitate the operational management of our customers.



Our objectives are:



To lead the sector inside our area, as well as searching the implementation both nationally and internationally.

To develop a strong, viable and long-lasting business project contributing with our experience and professionalism.

Provide the necessary return to medium and long term to ensure the development of our project thanks to the involvement between supplier and customer.

Offer to our clients the necessary solutions in products and service that contribute to its satisfaction, with a permanent stock and a variety of active references and many others in management.

Create a climate of trust in the relationship between our staff, customers and suppliers.

Suministros Industriales Furio

Director Comercial



Jose Furio

Departamento Comercial



Antonio Furio



Rosa Bayo



Silvia Lacruz



Gemma Martínez

Dpto. de Marketing

Departamento de Compras y Ventas



Trini Gil



Cristina Ramos



Jorge Chaume

Departamento de Administración



Merche Tripliana

Almacén



Enrique Grangel



Andrea Lungu



Eva Abril



Noelia Sánchez

Departamento de Logística



Fran Cuevas



Dani Monferrer



Rubén Segura

Formación y Prevención Furio

Formación y Prevención Furio S.L. nace en el año 2017 con el objetivo de establecerse y liderar en el sector de la formación y prevención para empresas y entidades.

Un equipo de profesionales multidisciplinares trabaja para disminuir la siniestralidad laboral a través de la formación en prevención de riesgos laborales, y el asesoramiento a las organizaciones, estableciendo técnicas y programas formativos.



Entre los principios básicos de Formación y Prevención Furio S.L. se desmarcan los siguientes:

Servicio al cliente y compromiso con la sociedad, el medioambiente y la salud.

Mejora continua en la calidad de los servicios y condiciones de trabajo, en busca de la excelencia empresarial.

Formación y cualificación a las personas, pues constituyen el valor más importante.

Impulso de actividades que no comprometan aspectos de **seguridad y salud**.

La formación puede impartirse en forma de cursos personalizados, adaptados a las necesidades y características de cada empresa, o también mediante cursos individuales, dirigidos a una única persona. Así pues, el catálogo se compone de más de una veintena de actividades formativas, todas ellas a la vanguardia de las necesidades y exigencias del mercado laboral, centrándose, sobre todo, en el sector cerámico.

Departamento de Formación y Comercial



Héctor Boix



Gerardo Luís

Dpto. de Administración



María Prades

Pre sen tes



en Cevisama

Edición de 2016

Edición de 2018

Edición de 2020



furio
suministros industriales

Nuestras marcas



Nuestras marcas



Nuestros productos

En **Suministros Furio** disponemos de un stock permanente de productos para la industria cerámica y empresas satélites, formado por una gran variedad de referencias activas.

Somos una empresa experimentada y dinámica. Por ello, estamos en constante evolución, incorporando nuevos productos a la vez que evoluciona el mercado. Así, uno de nuestros pilares es atender a las exigencias y necesidades de nuestros clientes, en unos tiempos de entrega reducidos, y a un precio competitivo.



Por otro lado, nuestro equipo de profesionales está totalmente cualificado y formado, y dispone de gran experiencia en el sector. Fruto del trabajo constante, logramos ofrecer una gran experiencia a nuestros clientes, informando y asesorando de manera individual y personalizada según sus demandas y necesidades. Por todo ello, Suministros Furio se ha convertido en una empresa referente.

A continuación, presentamos nuestro **catálogo oficial**, en el cual pueden apreciarse los productos industriales de mayor y más habitual consumo en el sector cerámico.



No obstante, no dude en ponerse en contacto con nosotros o con nuestros comerciales, que tratarán de dar una solución de forma rápida y profesional. O si lo prefiere, puede venir a visitar nuestra empresa para conocerlos y ver de primera mano nuestro stock.



- Rodamientos -



- Soportes -





- Rótulas -



- Soportes pie -





- Rodamiento lineal -



- Casquillos -





- Instrumentos -



- Grasas -



- Alquiler de calentadores de inducción para rodamientos -

Calentador de inducción para rodamientos muy grandes (Serie TIH 240)

- Calienta rodamientos de 445 kg en solo 10 minutos
- Diseñado para un fácil transporte con carretilla elevadora
- Desmagnetización automática
- Puede calentar rodamientos obturados y lubricados de por vida
- 3 años de garantía



Características técnicas

Especificaciones	Designación	Voltaje
Otras potencias disponibles bajo pedido	400 V y 460 V	50 Hz y 60 Hz
Consumo máximo de potencia	24 kVA	
Peso máximo recomendado	Rodamientos de 700 kg	
Otras piezas	300 kg	
Control de temperatura		
Rango	0 - 250 °C	
Sonda magnética	•	
Precisión (electrónica)	3 °C	
Control de tiempo		
Rango	0 - 60	
Precisión	0,01 s	
Área de trabajo	330 x 355 mm	
Dimensiones	750 x 400 x 935 mm	
Peso con yugo	300 kg	
Yugo estándar	100 x 100 x 570 mm	

Calentador de inducción (Serie TIH 030 230V)

- Tecnología punta electrónica y óptima desmagnetización
- Protección por sobrecalentamiento
- Opción de potencia reducida
- Puede calentar rodamientos obturados y prelubricados
- 3 años de garantía



Características técnicas

Especificaciones	Designación	Voltaje
Otras potencias disponibles bajo pedido	230 V	50 Hz y 60 Hz
Consumo máximo de potencia	3,5 kVA	
Peso máximo recomendado	30 kg	
Control de temperatura		
Rango	0 - 250 °C	
Sonda magnética	•	
Precisión (electrónica)	3 °C	
Control de tiempo		
Rango	0 - 60	
Precisión	0,01 s	
Área de trabajo	130 x 95 mm	
Dimensiones	290 x 255 x 225 mm	
Peso calentador	19 kg	
Peso con yugos	27 kg	



- Rodamientos -





- Rodamientos -



- Rodamientos -



- Rótulas -



- Sistemas de guiado lineal -



- Rodamientos de aguja -



- Casquillos -



- Patines y guías -

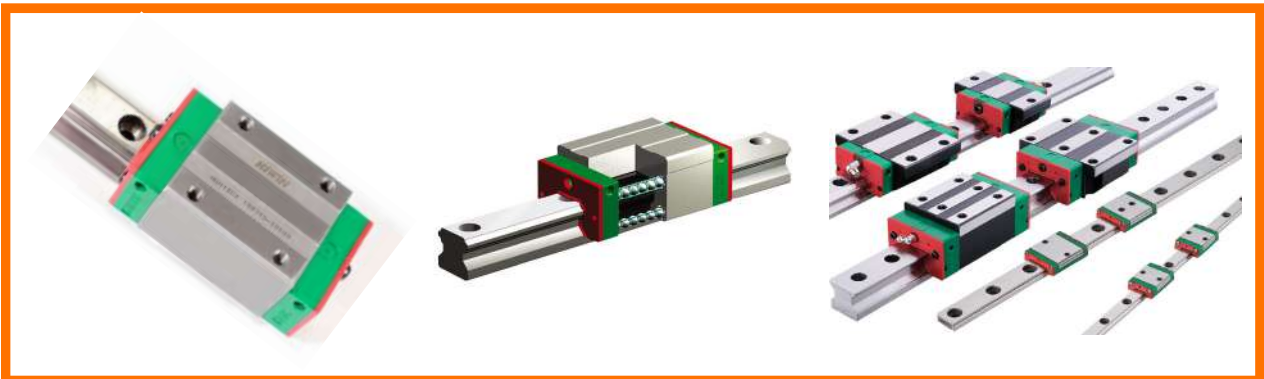

- Patines y guías -

TBK

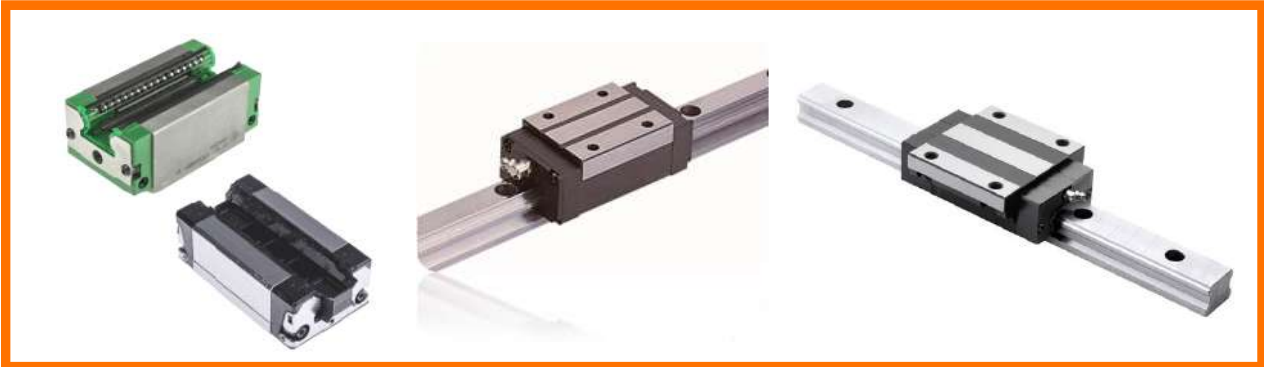

igus



INA



- Patines y guías -

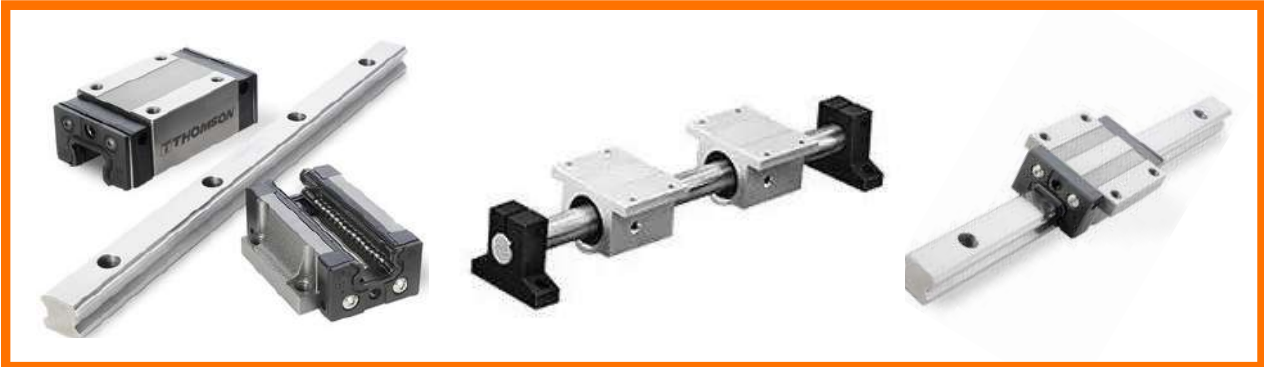

- Patines y guías -



Innovation, Know-how & Originality



- Rodamientos y guías -



- Rodamientos y soportes antirretorno -





- Retenes y juntas tóricas de nitrilo y viton -

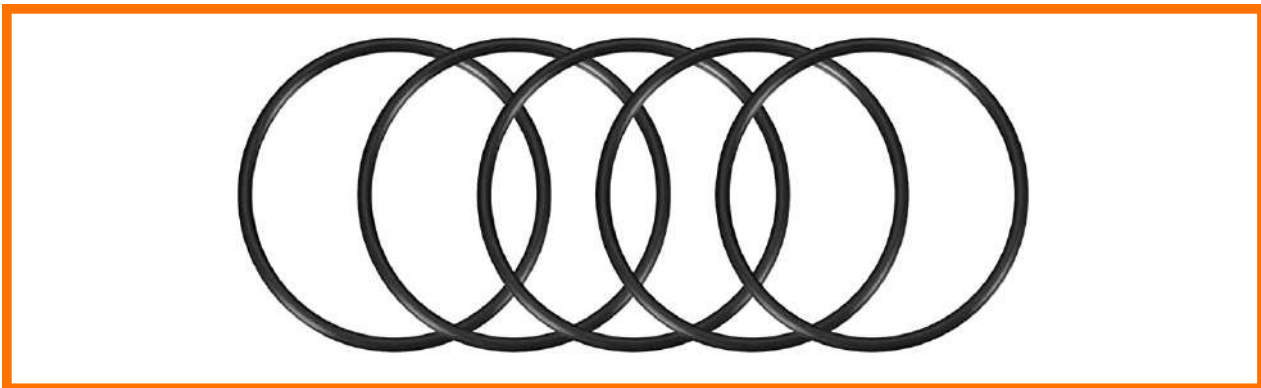
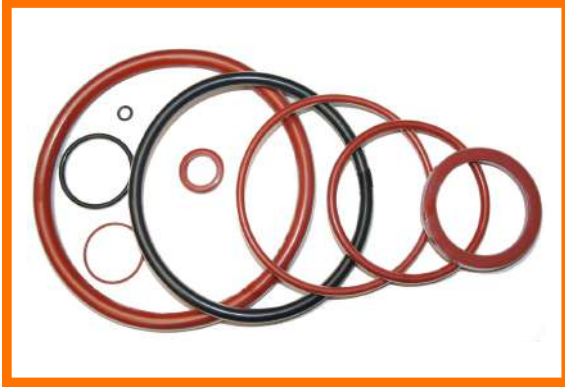



- Cierres mecánicos -



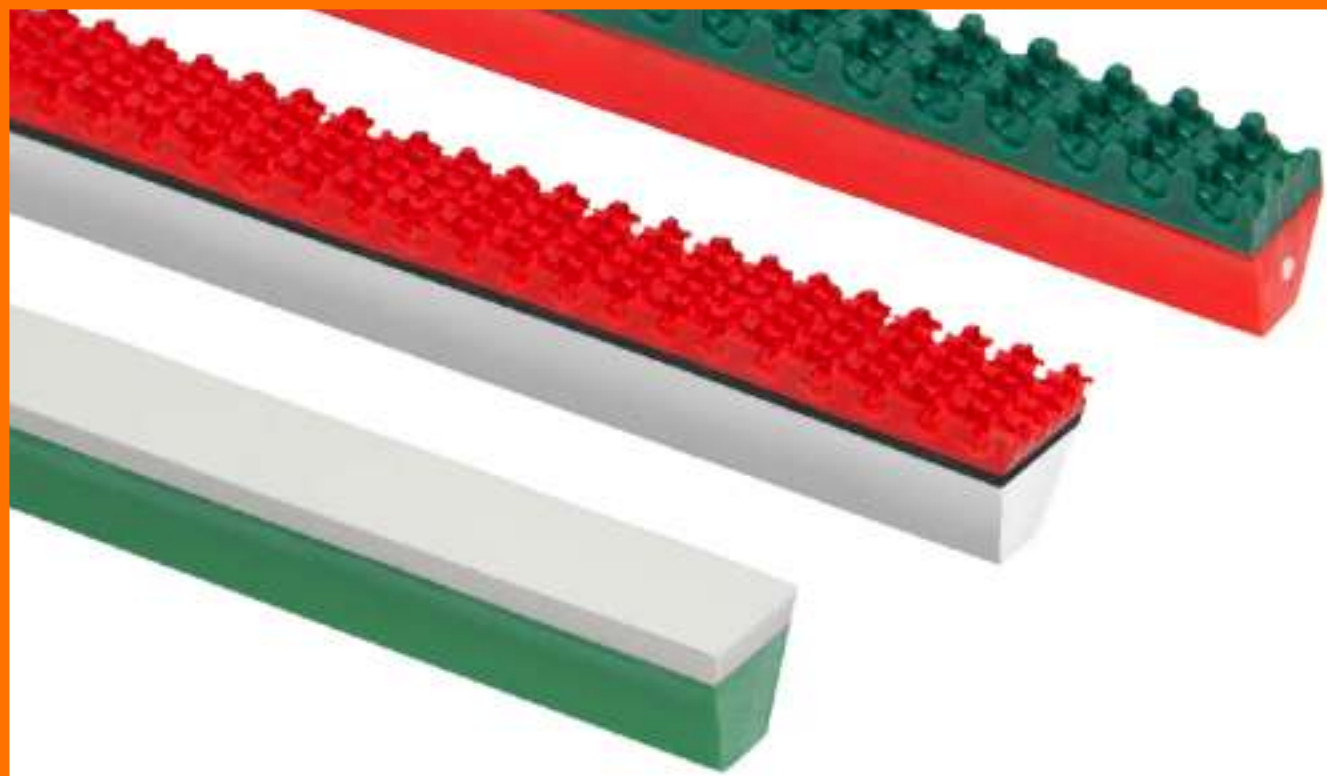

4-belt

Ensure
your Power

Correas Termosoldables - Accesorios para bandas transportadoras



- Correas redondas -



- Correas tubulares -



- Correas trapezoidales dentadas -

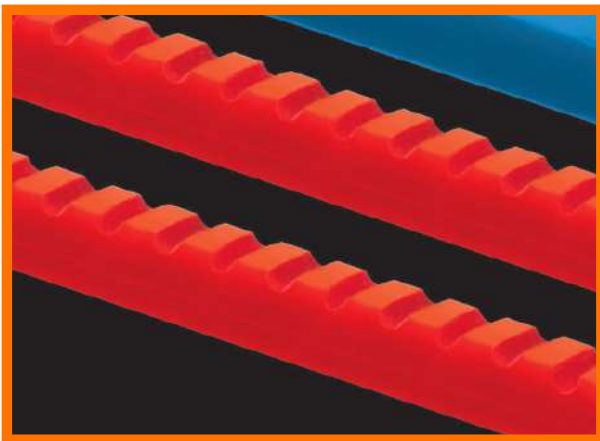

- Correas trapezoidales -



- Correas trap. con revestimiento -

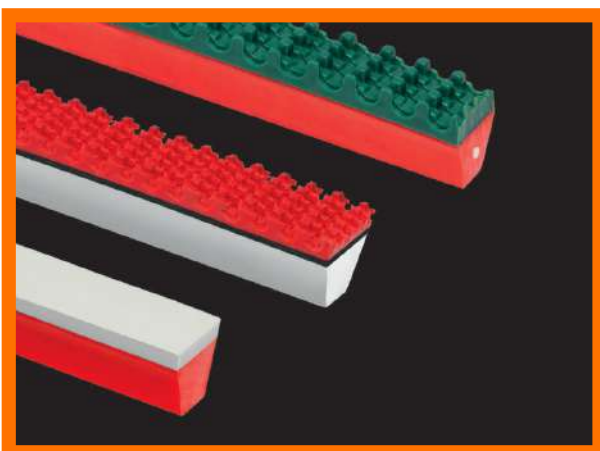

- Correas con cresta -

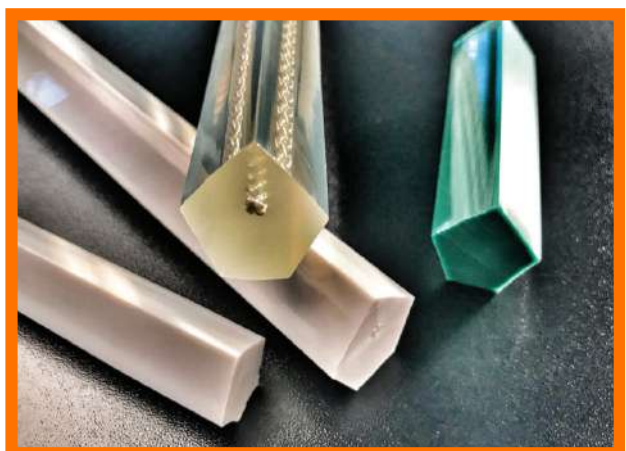

- Correa termosoldable -



- Utensilios para unir correas -

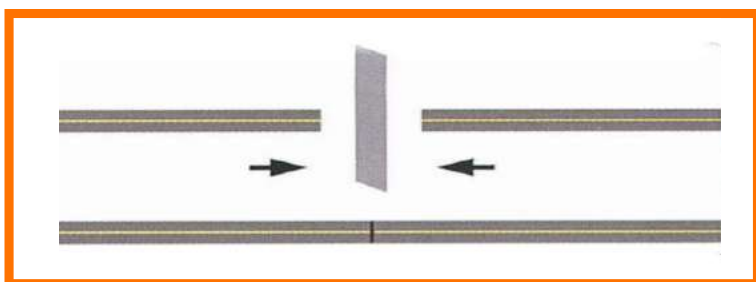
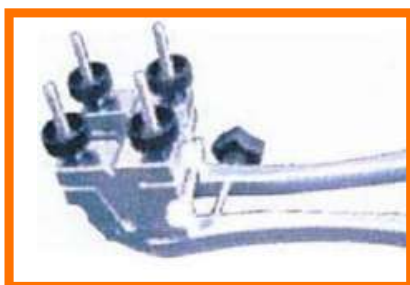

- Pneumático para unión overlap -

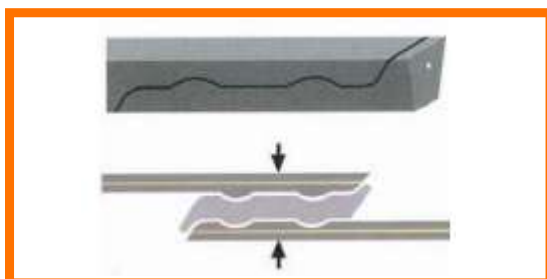



- Correas industriales -

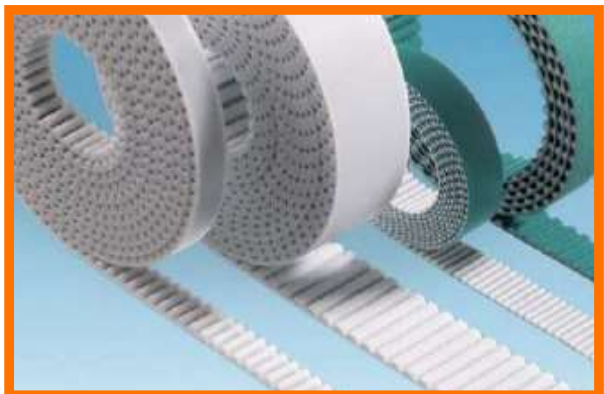
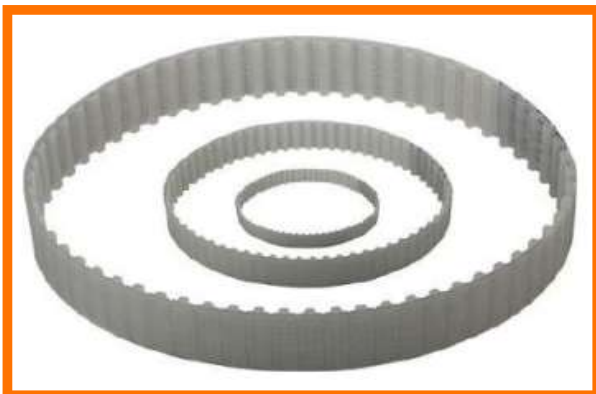

- Línea de producción cerámica -

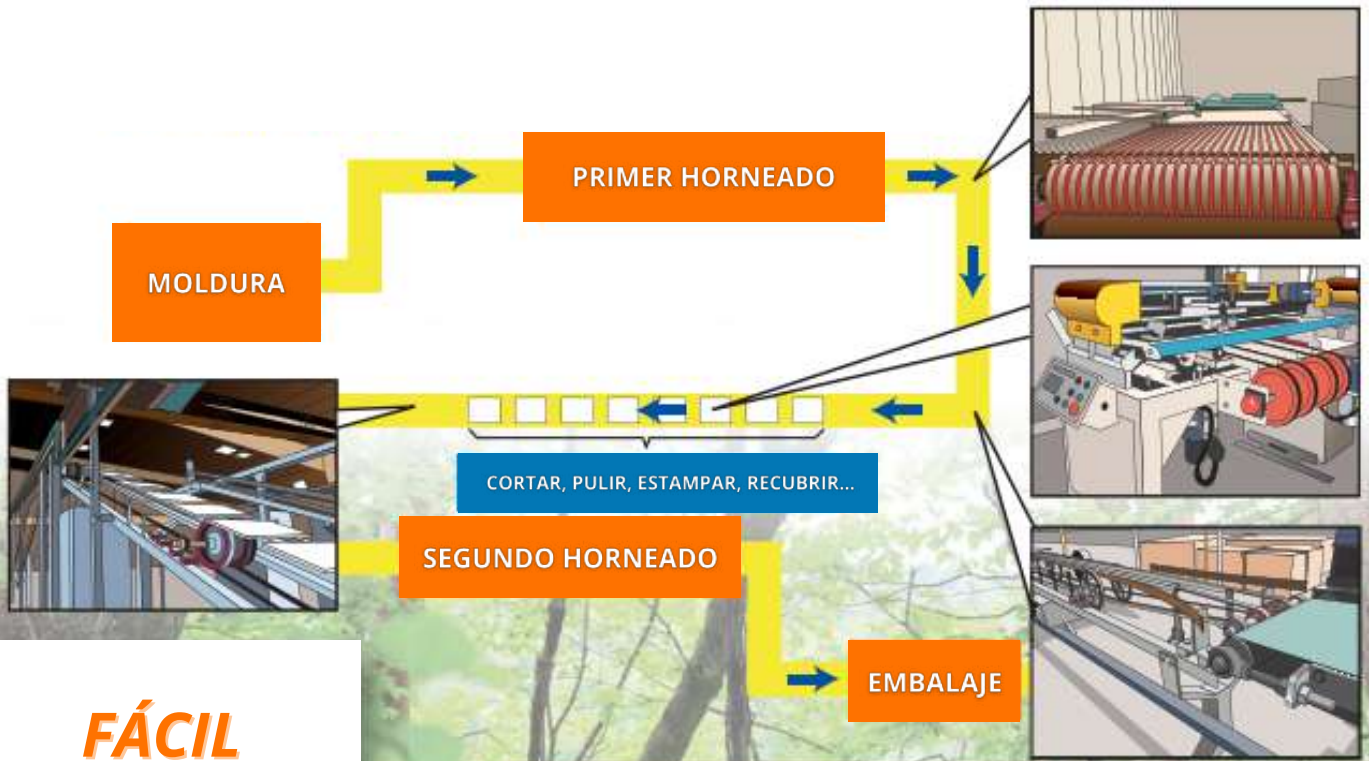

FÁCIL
SEGURO
DURADERO

Transporte seguro de las piezas en la parte posterior plana de las bandas

No se necesita reemplazar poleas

¡Gruosa y duradera!

- Línea de producción cerámica -

Características

Vida duradera

Gruesa y construida de caucho resistente a la abrasión, con más del doble de vida que las correas tradicionales.

Seguro

La parte trasera de la correa es plana, por lo que los azulejos no se caen cuando se desplazan por las líneas.

Sencillo

Instalación con bajo coste, ya que se pueden utilizar las poleas existentes.

Aplicaciones

En la industria de la cerámica, las correas son ideales para el proceso de la sección de hornos, donde los productos experimentan una vida útil corta. Estas correas también se pueden usar en otras industrias en las cuales se transportan otros productos planos en la parte trasera de la correa.

Precaución: estas correas no se pueden usar en aplicaciones de transmisión de potencia como aires acondicionados o compresores.

Comparación

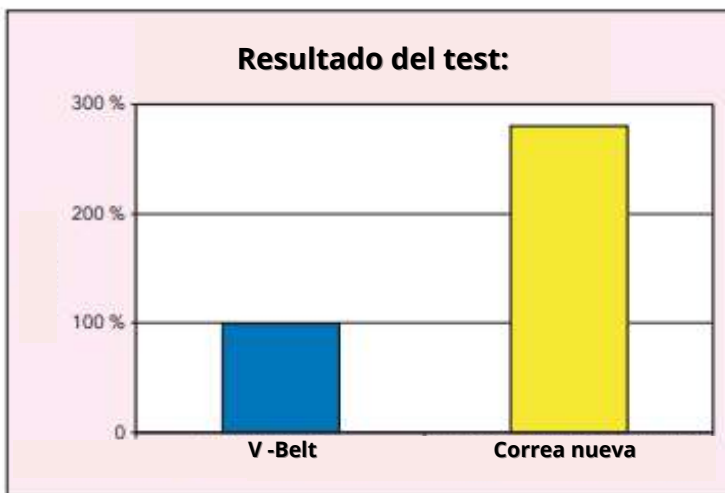

Condiciones:

Tiempo de operación: 12-24 horas/día
Correa de comparación: Bando V-Belt

¡Más del doble de vida útil!
Comparada con Bando V-Belt

Rango de tamaño estándar

Longitudes estándar	
Sección B	138 - 490 inch
Sección C	140 - 450 inch

*Contacta con nosotros si necesitas otras medidas

- Correa a metros en poliuretano -

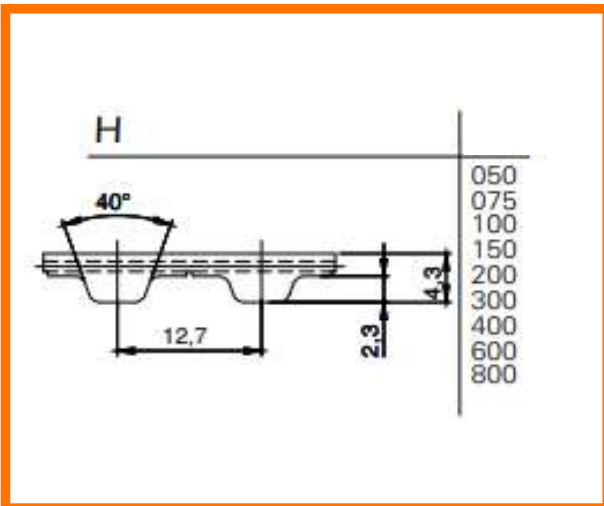

DESCRIPCIÓN
Correa PU H 075
Correa PU H 100
Correa PU H 150

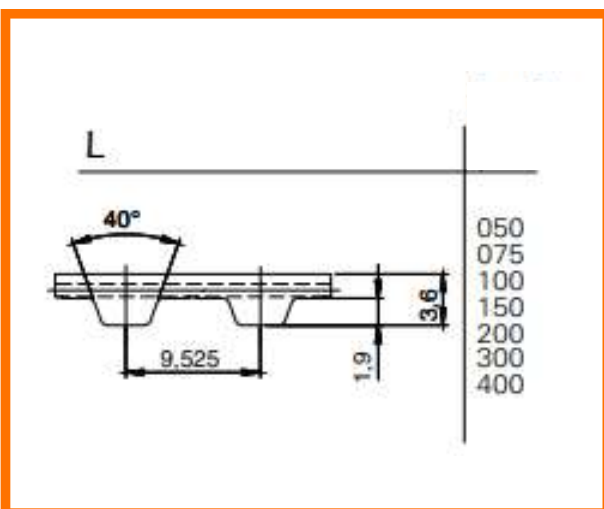

DESCRIPCIÓN
Correa PU L 050
Correa PU L 075
Correa PU L 100

- Correa a metros en poliuretano -

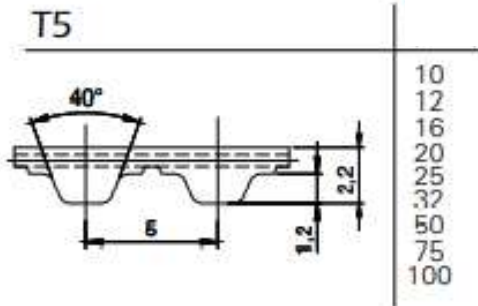

DESCRIPCIÓN

Correa PU T5 M10

Correa PU T5 M16

Correa PU T5 M25

Correa PU T5 M32

Correa PU T5 M50

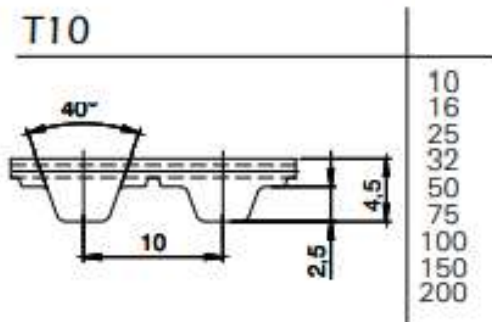

DESCRIPCIÓN

Correa PU T10 M10

Correa PU T10 M20

Correa PU T10 M25

Correa PU T10 M32

Correa PU T10 M50

- Correa a metros en poliuretano -

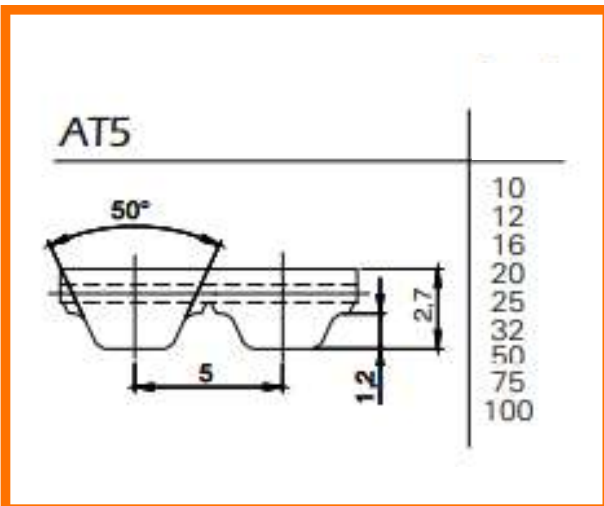

DESCRIPCIÓN
Correa PU AT05 M10
Correa PU AT05 M16
Correa PU AT05 M25
Correa PU AT05 M32
Correa PU AT05 M50

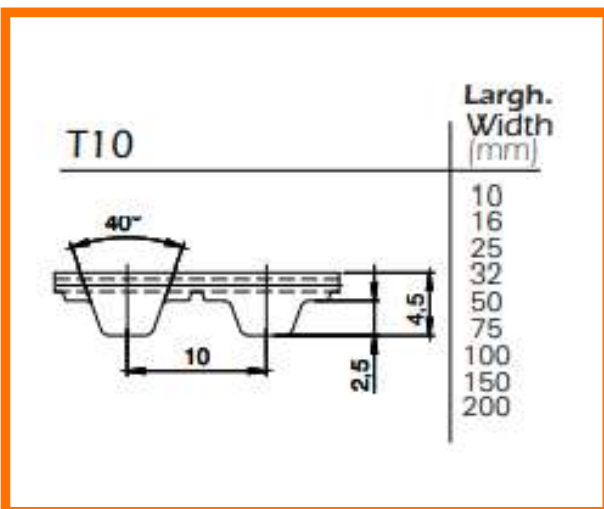

DESCRIPCIÓN
Correa PU AT10 M10
Correa PU AT10 M16
Correa PU AT10 M25
Correa PU AT10 M32
Correa PU AT10 M50
Correa PU AT10 M100

- Correa a metros en poliuretano + NFT -

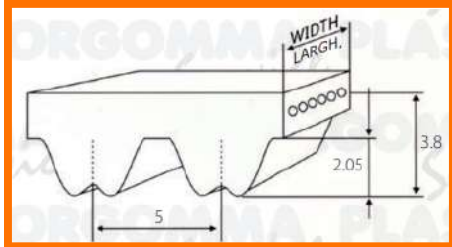

DESCRIPCIÓN

Correa PU RPP5 M10 NFT

Correa PU RPP5 M15 NFT

Correa PU RPP5 M22 NFT

Correa PU RPP5 M25 NFT

Correa PU RPP5 M50 NFT

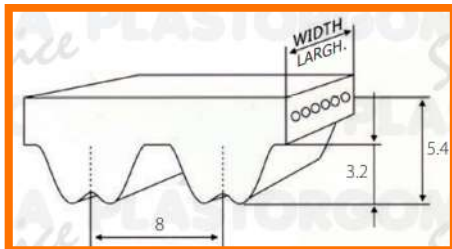

DESCRIPCIÓN

Correa PU RPP8 M15 NFT

Correa PU RPP8 M20 NFT

Correa PU RPP8 M30 NFT

Correa PU RPP8 M50 NFT

Correa PU RPP8 M85 NFT

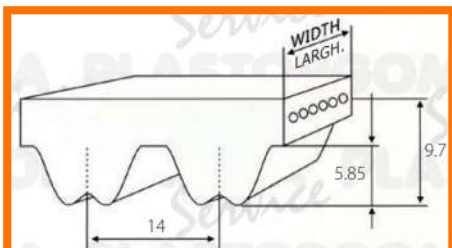

DESCRIPCIÓN

Correa PU RPP14 M40 NFT

Correa PU RPP14 M55 NFT

Correa PU RPP14 M85 NFT

- Correa modular -



- Correas crestadas en caucho -



- Correa para línea de selección -



MEDIDAS
SIZES
20x12,5x7900
20x12,5x9020
20x12,5x10460
20x12,5x10950
20x12,5x11900
20x12,5x13280
20x12,5x14550
20x12,5x14760
20x12,5x16160
20x12,5x17160
20x12,5x17420
20x12,5x17640
20x12,5x19070
20x12,5x19700
20x12,5x20180
20x12,5x20510
20x12,5x21950

CÓDIGO
CODE EXAMPLE
0912B



MEDIDAS
B433
B512
B551
B583
B553
B612
B669
B785

GRUPO DEL PRODUCTO
091B

Revestimiento especial antidesgaste

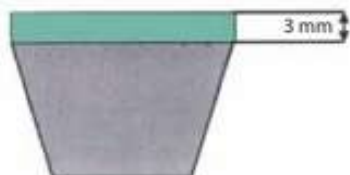

Color azul

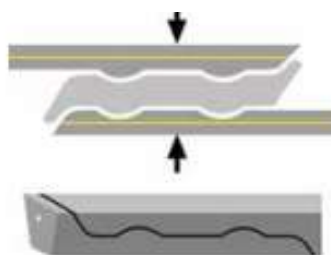

Disponibles todas las medidas bajo demanda

- Correa para línea de selección recubierta en poliuretano especial -

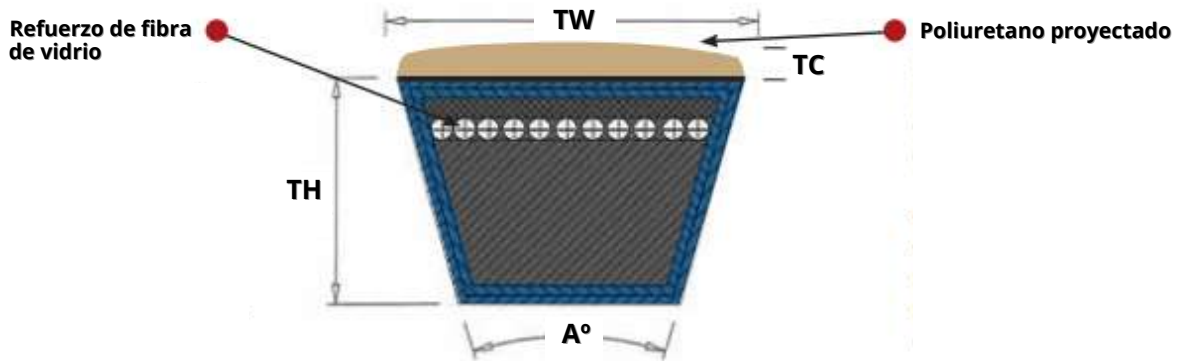

Sección	Ancho superior	Altura	Esp. recubrimiento	Ángulo
B	17 ± 0,50 mm	11 ± 0,50 mm	2 mm	40° ± 1°
B	19,5 ± 0,50 mm	12,5 ± 0,50 mm	2 mm	40° ± 1°

CORREA PARA LÍNEA DE SELECCIÓN

DISPONIBLE EN TODOS LOS TAMAÑOS

MEDIDAS	MEDIDAS	MEDIDAS
20x12,5x7900	20x12,5x17160	B433
20x12,5x9020	20x12,5x17420	B472
20x12,5x10460	20x12,5x17640	B512
20x12,5x10950	20x12,5x19070	B551
20x12,5x11900	20x12,5x19700	B553
20x12,5x13280	20x12,5x20180	B583
20x12,5x14550	20x12,5x20510	B612
20x12,5x14760	20x12,5x21950	B669
20x12,5x16160		B785

- Correa para salida de horno -

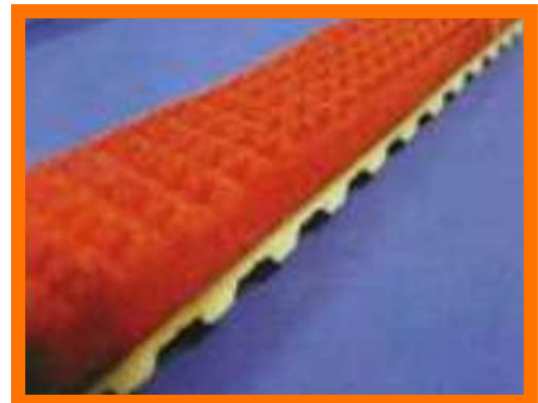

- Correa para rectificadora -

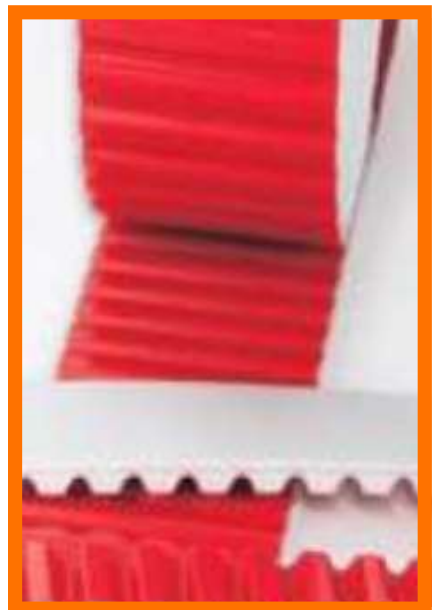



- Transmisión -

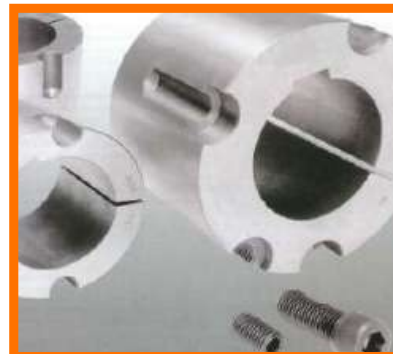

- Acoplamientos -



- Acoplamientos GEAR -



- Acoplamientos -

samiflex®



nil-uni3n.



PAGUFLEX®



KTR



furio
suministros industriales

- Cadena robótica -



- Perfiles APM / Poligur -

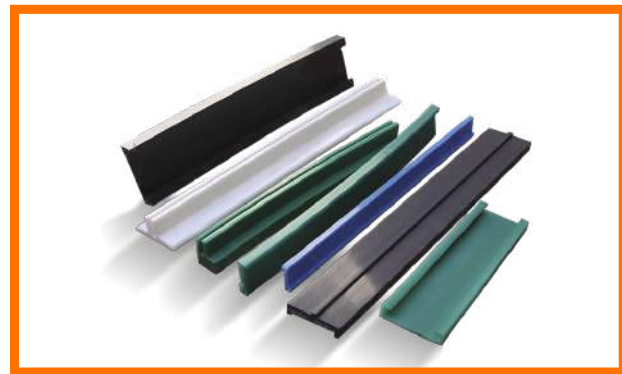
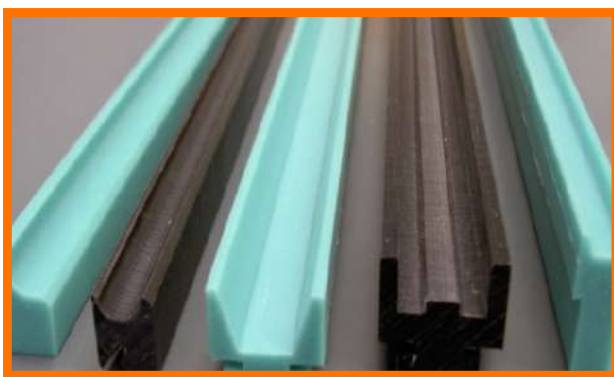
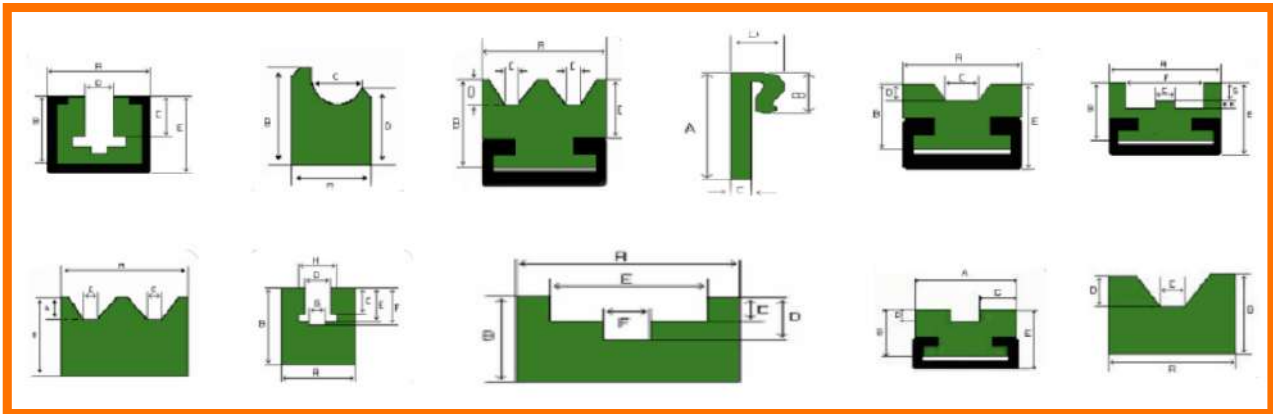

- Vulcanizado de piezas en poliuretano -

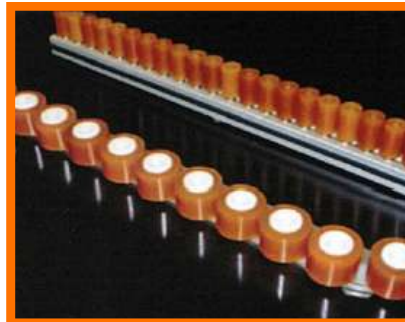
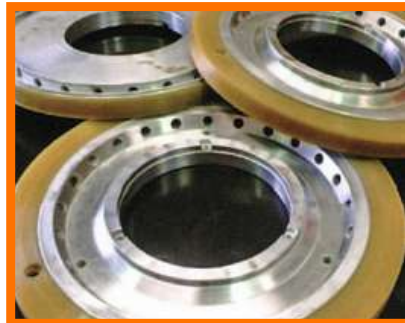



- Discos de corte, discos de lija, abrasivos -



- Soportes antivibrantes / silentblocks -





Bridas rápidas



Chavetas



Pies niveladores



Elementos de maniobra



Cáncamos giratorios de elevación



Accesorios perfil de aluminio



Tornillería de nylon



Tornillería alta calidad



Insertos para roscas

- Tornillería PAV-ZINC-INOX -



- Abrazaderas, segers, grilletes, cáncamos -



- Válvulas de esfera -



- Recambios para impresoras Inkjet -



- Filtros -



SPNFIL003
FILTRO PALL MACWA-1003
PALL FILTER MACWA-1003



SPNFIL001
FILTRO PALL MACCA-0501
PALL FILTER MACCA-0501



SPNFIL010
FILTRO + CONECTORES
FILTER + CONNECOTRS



SPNFIL007
FILTRO BLANCO 5um
WHITE FILTER 5um

- Bomba -



SPNPOM006
BOMBA WELCO WP10
WELCO PUMP WP10

- Tubo -

TYGON



FLOJET®

- Bombas -



Ref. G575205A

- Papel / anticongelante -



Ref. 530137



- Pies giratorios -



REFERENCIA	DESCRIPCIÓN
PIE120H200M16	Pie giratorio M16X200 ZINCADO
PIE120H200	Pie giratorio M20X200 ZINCADO
PIE120H20024	Pie giratorio M24X200 ZINCADO



REFERENCIA	DESCRIPCIÓN
PIE120H200M16I	Pie giratorio M16X200 INOX
PIE120H200M20I	Pie giratorio M20X200 INOX
PIE120H200M24I	Pie giratorio M24X200 INOX

- Fleje acero templado -



REFERENCIA	MEDIDA
599REGG20X02	20X2
599REGG25X02	25X2
599REGG30X02	30X2
599REGG40X02	40X2
599REGG45X02	45X2
599REGG50X02	50X2
599REGG60X02	60X2
599REGG80X02	80X2



- Equipos de lubricación -





- Grasas -



- Aceites -



- Espráis técnicos -





- Adhesivos y sellantes -



Siliconas



Siliconas



Poliuretanos



Polimeros

- Otros -



- Higiene -





- Multiusos -



- Selladores, espumas y adhesivos -



Cyano
127374



T-Rex Turbo
124717



T-Rex Cristal
16118694



T-Rex Power
131060

- Cintas y adhesivos -



- Productos químicos -



- Limpieza industrial -



- Limpieza -



CÓDIGO	DESCRIPCIÓN
402010001	Cubo redondo con escurridor 12L
2703136	Cubo redondo 8L
402005000	Cubo de basura con pedal 22L
2703140	Cubo de basura 100L + Tapa



CÓDIGO	DESCRIPCIÓN
2701359	Fregona de hilos finos
2703145	Fregona tipo bayeta
2703146	Palo universal de titanio
2703147	Recogedor con palo
2703148	Kit de recogedor + cepillo

- Pilas -



CÓDIGO	DESCRIPCIÓN
9000311	Pila alcalina PHILIPS LR03 (AAA) Blíster 4 Ud.
9000312	Pila alcalina PHILIPS LR6 (AA) Blíster 4 Ud.
9000313	Pila alcalina PHILIPS LR14 (C) Blíster 2 Ud.
9000314	Pila alcalina PHILIPS LR20 (D) Blíster 2 Ud.
9000315	Pila alcalina PHILIPS 9V (ET3) Blíster 1 Ud.
9000115	Pila alcalina petaca plus 3LR12



CÓDIGO	DESCRIPCIÓN
9000142	Pila alcalina ultra M3 123
9000143	Pila alcalina ultra M3 CR2
9000140	Pila alcalina MN21
9000144	Pila alcalina N/LR1
9000145	Pila alcalina ultra M3/AAA



CÓDIGO	DESCRIPCIÓN
9000155	Pila alcalina 377
9000159	Pila alcalina CR2016
9000160	Pila alcalina CR2025
9000161	Pila alcalina CR2032
9000152	Pila alcalina DL2450



CÓDIGO	DESCRIPCIÓN
9000153	Pila alcalina LR44
9000154	Pila alcalina 364
9000141	Pila litio MN27
9000151	Pila litio DL2430



CÓDIGO	DESCRIPCIÓN
9000146	Pila litio DL1220
9000062	Pila litio DL1616
9000162	Pila litio DL1620
16000001	Pila litio 1632

- Cúter, rasqueta y linternas -



CÓDIGO	DESCRIPCIÓN
2100457	Recambio 10 cuchillos para cúter
2100675	Cúter plástico 3 cuchillos



CÓDIGO	DESCRIPCIÓN
2101442	Rasqueta
2101443	Cuchilla recambio para referencia 002101444
2101444	Rasqueta profesional con mango
2101445	Cuchilla recambio para referencia 002101444



CÓDIGO	DESCRIPCIÓN
1600889	Linterna 9 LEDs de aluminio
1603251	Linterna cabeza LED COB. Lúmenes: 80 Lm.
1603215	Linterna rectangular LED COB. Lúmenes: 15 Lm.
201800000	Linterna multiusos 5W recargable
600197	Lámpara portátil industrial 10M
600742	Lámpara portátil industrial 5M
600136	Tubo fluorescente portátil

- Productos de ordenación -



- Racores y accesorios -



- Enchufes rápidos -



- Cilindros -



- Tubería técnica -



- Válvulas -



- Válvulas con actuador -



- Manómetros -



- Redes -



- Tubería industrial -



Klef-10



Compresair-20



Multithor-10



Spring



Cristal



Cristal reforzado



Garden TM



Garden TM reforzado



Impulsión líquidos
superelástica



Aspiración abrasivos



Plana negra



Impulsión abrasivos
12 Bar

- Tubería industrial -

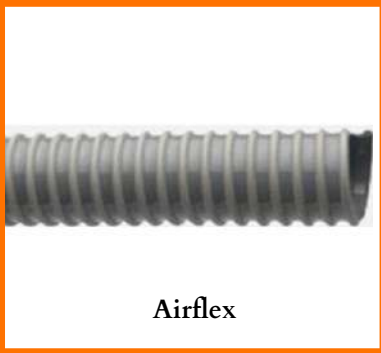

Airflex

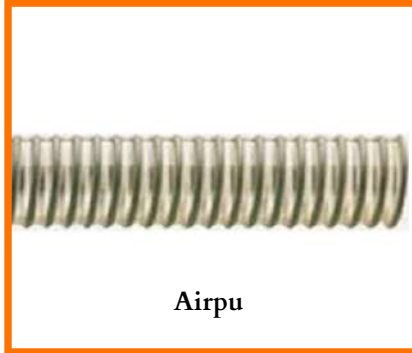

Airpu

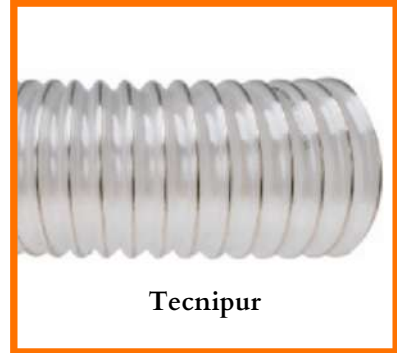

Tecnipur



Vena HTD



Aluminio



Metálico TAD

- Racores rótula: hierro galvanizado-acero inoxidable -



Enlace gatillo manguera



Rótula manguera



Enlace gatillo rosca macho



Rótula rosca macho



Enlace gatillo curvo manguera



Rótula rosca hembra



Aro de rótula bola



Rótula tapón

- Racores Gillemin: aluminio-acero inox-polipropileno-bronce -



Reducción con
cierre



Rosca hembra
con cierre



Rosca macho
con cierre



Tapón
con cierre

- Racores Kamlock: aluminio-acero inox-polipropileno-bronce -



Tipo A



Tipo B



Tipo C



Tipo F

- Planchas -



Plancha de caucho
común (negro)



Plancha de caucho
natural virgen



Plancha de nitrilo



Plancha de poliuretano



Plancha de silicona



Plancha de caucho
esponjosa (roja)

- Rulos abrasivos para desbarbar en seco -



CÓDIGO	DESCRIPCIÓN	DIMENSIONES
E371467	Rulo abrasivo azul	150x40x50
E371468	Rulo abrasivo azul	150x50x50
E371469	Rulo abrasivo	150x80x50
E371470	Rulo abrasivo azul	150x90x50
E371471	Rulo abrasivo azul	150x100x50
E371486	Rulo abrasivo	150x550x50
E371487	Rulo abrasivo	150x700x50
E371410	Rulo abrasivo	200x50x76,2

- Tubo para forrar rodillos PVC + neopreno, PU y silicona -

Tubo liso
Hasta 120°



CÓDIGO	DESCRIPCIÓN
CODE	DESCRIPTION
406PUTR25x30	Guaina liscia 25x30
406PUTR27x32	Guaina liscia 27x32
406PUTR30x35	Guaina liscia 30x35
406PUTR32x37	Guaina liscia 32x37
406PUTR35x40	Guaina liscia 35x40
406PUTR38x43	Guaina liscia 38x43
406PUTR40x45	Guaina liscia 40x45
406PUTR45x50	Guaina liscia 45x50
406PUTR48x53	Guaina liscia 48x53
406PUTR50x55	Guaina liscia 50x55
406PUTR60x65	Guaina liscia 60x65



Tubo rayado
Hasta 120°



CÓDIGO	DESCRIPCIÓN
CODE	DESCRIPTION
406PUTR25x30R	Guaina rigata 25x30
406PUTR27x32R	Guaina rigata 27x32
406PUTR30x35R	Guaina rigata 30x35
406PUTR32x37R	Guaina rigata 32x37
406PUTR35x40R	Guaina rigata 35x40
406PUTR38x43R	Guaina rigata 38x43
406PUTR40x45R	Guaina rigata 40x45
406PUTR45x50R	Guaina rigata 45x50
406PUTR48x53R	Guaina rigata 48x53
406PUTR50x55R	Guaina rigata 50x55
406PUTR60x65R	Guaina rigata 60x65



Los tubos, recubiertos en silicona roja, son recomendables para trabajos en temperaturas elevadas de hasta 200°C.

Tamaños disponibles según el lote de producción y el molde.

GRUPO PRODUCTO
406 SILR

- Tubo para forrar rodillos PVC + neopreno, PU y silicona -



Diámetros	Diámetros
24x27	38x44
26x30	39x43
26x31	39x45
27x30	40x42
27x32	40x44
28x38	40x45
30x34	45x50
30x36	48x52
31x35	48x53
31x39	48x54
32x37	49x43
34x39	49x53
34x40	50x54
35x39	50x55
35x41	50x56
36x40	50x58
38x42	

PVC 70° / PVC + NEOPRENO 120°

Los tubos de PVC se dividen en dos grupos:

- PVC normal
- PVC + NEOPRENO resistente al calor

El tubo de PVC normal tiene una temperatura máxima de trabajo de 70°C

El tubo de PVC + neopreno tiene una temperatura máxima de trabajo de 120°C

DISPONIBLE EN LAS SIGUIENTES VERSIONES:

Liso y rayado

***Otras medidas disponibles bajo demanda**

GR. MERCEOLÓGICO GRUPO PRODUCTO

406 PVC
406 PVC+N

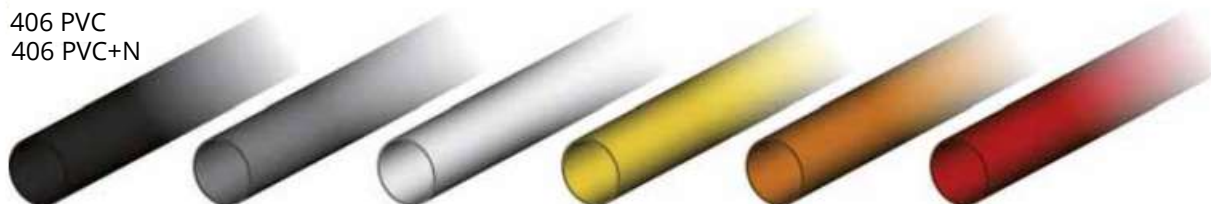

Colores disponibles: Negro, Gris, Blanco, Amarillo, Naranja y Rojo



TAMAÑO mm

Ø30x40x500
Ø34x42x500
Ø40x50x500
Ø45x58x500
Ø45x60x500
Ø50x60x500
Ø32x42x1000
Ø40x45x1000

Rectificado



GRUPO PRODUCTO

403 TSPING

***Otras medidas disponibles bajo demanda**

- Boquillas soplado, accesorios y válvula contador aire -

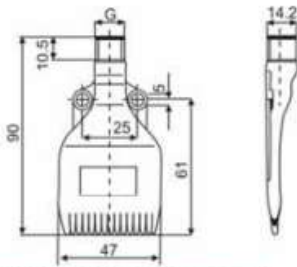

**BOQUILLA SOPLADORA
PEINE (AZUL)**
COD. 617069523



REPARADOR 2x3/8-4x1/a
COD. 611RYS991311
Dim. 198L.X29Hx20sp.



**DISTRIBUIDOR
MODULAR
COMPLETO**



RACOR EMPALME
COD. 615NC2603838

VÁLVULA DE OBTURACIÓN DE PVC



388VALVSE080
Ø 80/ 90 / 100/ 120/
150/ 170/ 200

VÁLVULA CLAPET



388CLAPET050 - Ø50
388CLAPET060 - Ø60

- Green Blow FM -

GREEN BLOW

Blasque per Ventiladors con transmissió d'enginyeria

→ **Mínors Consums!** potenciant del motor, prestacions millors (un sol 0,3 kW de potència instalada)

Peça Refredada (altes 2-40%)

→ **Mínors Rruensures!** orientables de 10° a 45°

→ **Completament Intercomutables** amb els models anteriors

Portada majorada del 25%

Mínors Rruensures! -40% con el difusor de 620 mm

Recorrido optimizado de 620mm, **mayor velocidad (+28%)** e **uniformidad** per una vera e propia terna d'aria

FM

NB: El color possible non representa quello della produzione in serie



COD.402120029001
GREEN BLOW 0,37Kw 620x6,3
SIN DIFUSOR

COD.402501003
DIFUSOR AJUSTABLE

COD.4021600080900
APOYO GREEN BLOW TEL.800

DIFUSOR DE LÁMINAS DE AIRE TRANSVERSALES

INCLINACIÓN REGULABLE 90°

***LONGITUD DEL DIFUSOR DISPONIBLE BAJO DEMANDA**



- Herramientas -

PARA MÁQUINAS



LIMAS



LLAVES



VASOS Y ACCESORIOS



HERRAMIENTAS DINAMOMÉTRICAS



ACCESORIOS PARA HERRAMIENTAS ELÉCTRICAS Y NEUMÁTICAS





- Herramientas -

HERRAMIENTAS PARA TRABAJOS EN ALTURA



HERRAMIENTAS AISLADAS



HERRAMIENTAS ANTICHISPA



HERRAMIENTAS DE ACERO INOXIDABLE



PINZAS Y HERRAMIENTAS ESPECIALES PARA ELECTRÓNICA



MEDICIÓN Y TRAZADO



HERRAMIENTAS PARA PARED



ARCOS DE SIERRA MANUALES



SERRUCHOS





- Herramientas -

FORMONES



TIJERAS Y CUCHILLOS



MORDAZAS Y TORNILLOS DE BANCO



MARTILLOS



HERRAM. FORESTALES Y DE TALA DE ÁRBOLES



CINCELES Y PUNTEROS DE CHAPISTA



PALANCAS



HERRAMIENTAS PARA PLANTACIÓN Y CULTIVO



HERRAMIENTAS DE PODA



HERRAMIENTAS NEUMÁTICAS DE EXTERIOR



HERRAMIENTAS DE PRECISIÓN LINDSTRÖM





- Herramientas -

DESTORNILLADORES



LLAVES HEXAGONALES TIPO ALLEN



ALICATES



LLAVES PARA TUBOS Y HERRAMIENTAS PARA FONTANERÍA



HERRAMIENTAS NEUMÁTICAS



HERRAMIENTAS INALÁMBRICAS





- Instrumentos de verificación y control -



- Almacenaje -



Armario modular
Ref. 856001000



Taquilla acero con cerradura
Ref. 856001312



Cajonera de 8 cajones
Ref. 856001169

- Barreras de protección -



Barrera de seguridad
Ref. 758139227



Barrera protección inoxidable
Ref. 758136243



Barrera de protección
Ref. 758130773

- Equipamiento de taller -



Polipasto eléctrico
Ref. 758613095



Polipasto eléctrico
Ref. 758613090



Polipasto eléctrico
Ref. 758130773

- Limpieza profesional -



Hidrolimpiadora agua fría
Ref. 7101441



Hidrolimpiadora agua fría
Ref. 7101851



Hidrolimpiadora agua fría
Ref. 7109628



Aspirador industrial
Ref. 7002135



Aspirador Flexcat
Ref. 7003271



Trolley para HDR
Ref. 7110010



Hidrolimpiadora agua caliente
Ref. 7002135



Hidrolimpiadora agua caliente
Ref. 7150781



Fregadora industrial
Ref. 7202055

- Carretillas -



Carretilla de acero SXWTD
Ref. 753000522



Carretilla plegable aluminio
Ref. 753000705



Carro con ruedas plegable
Ref. 753000712

- Mesas elevadoras -



Mesa elevadora en tijera
Ref. 6150500



Mesa elevadora en tijera
Ref. 6154100



Mesa elevadora en tijera
Ref. 6100300

- Transpaletas -



Transpaleta PHW 2506
Ref. 6152506



Transpaleta EHW 20
Ref. 6160120



Transpaleta y mesa elevadora
Ref. 6150104

- Herramientas para metal -



Prensa hidráulica WPP20
Ref. 4001020



Prensa hidráulica WPP20
Ref. 6300050



Prensa Unicraft WPP 75E
Ref. 6300075



Sierra cinta P/metal
Ref. 3630125



Sierra cinta para trabajos metal
Ref. 3300210



Sierra cinta S
Ref. 3300285



Curvadora BM 3
Ref. 3244030



Curvadora RBM 305
Ref. 3780112



Curvadora perfiles motorizada
Ref. 3812031

- Herramientas para metal -



Taladro de columna y sobremesa
Ref. 3008203



Taladro de columna B32 (400 V)
Ref. 3008323



Taladro para engranajes DH
Ref. 3034240



Curvadora hidráulica HRB 10
Ref. 3777010



Curvadora UB 10
Ref. 3776010



Curvadora para tubos manual
Ref. 3776030



Esmeriladora de banco GU 20
Ref. 3101515



Esmeriladora ES 150/200
Ref. 350290



Esmeriladora Opti combinada
Ref. 3101575

- Herramientas para metal -



Plegadora manual HSBM 610 HS
Ref. 3772610



Plegadora de chapa manual
Ref. 3772125



Cizalla manual PS 300
Ref. 3241012



Fresadora de sobremesa MH
Ref. 3338155



Fresadora Opti Mum
Ref. 3336005



Torno TU 2500
Ref. 3425001



Juego de cuchillas HM 16 mm
Ref. 3441610



Pulv. lubricante y refrigerante
Ref. 3356663



Cono Morse MT5
Ref. 3050675

- Herramientas de medición -



Multímetro de bolsillo 210
Ref. 198650103



Pinza amperimétrica Limit 20
Ref. 128560109



Multímetro digital Limit 400
Ref. 190180109

- Herramientas para madera -



Rodillos con soporte
Ref. 5900005



Caballete extensible
Ref. 5900007



Caballete de trabajo extensible
Ref. 5900009



Sierra de cinta
Ref. 5900410



Sistema de aspiración
Ref. 5922201



Sistema de aspiración
Ref. 5922303

- Herramientas de soldadura -



- Herramientas de aire comprimido -

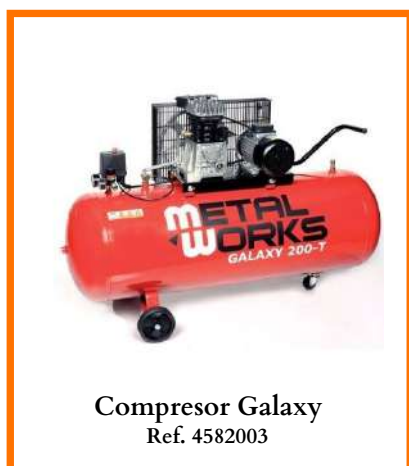

- Ventiladores y calefactores -



- Equipos de soldadura -



- Soldadura: consumibles, antorchas y accesorios -



- Herramienta de corte y accesorios -



- Herramienta eléctrica y baterías -



- Herramienta neumática y taladros columna -

AIXIA



YAIM
MAQUINARIA



furio
suministros industriales

- Escaleras y andamios -



- Sistemas para la aplicación de sellantes y adhesivos -





- Imanes -



Parrilla magnética



Base magnética



Separadores magnéticos



Imán herradura



Rodillos magnéticos



Etiquetas magnéticas



Base magnética



Bloques magnéticos



Elevadores magnéticos



Puente agujeros pasantes



Placa magnética

- Cepillería industrial -

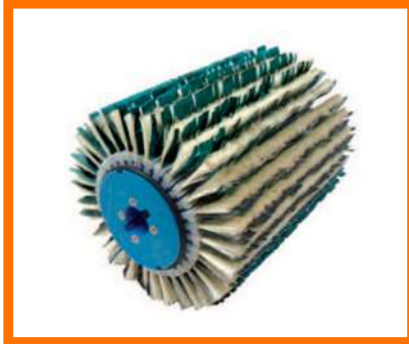

- Cepillos industriales para limpieza -

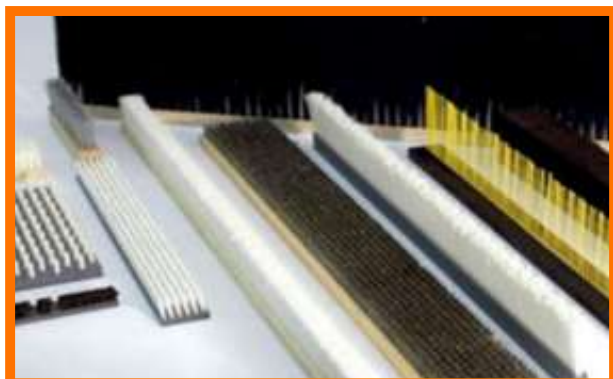

- Ruedas industriales de nylon -



- Ruedas industriales de poliuretano -



- Ruedas industriales de goma -



- Ruedas temperaturas extremas -



- Rodillos transpaletas -



- Zapatos serraje / cordura -



ACEBO S1/S1P

EVOLUTION



ACEBO FRESH S2/S3

BIOMECHANIC DUATLON



ACEBO CM S1/S1P

BIOMECHANIC DUATLON



INCA S2/S3

BIOMECHANIC TRIATLON



CONDOR S2/S3

BIOMECHANIC HEPTATLON

- Zapatos piel -



CASTAÑO S2/S3

EVOLUTION



OLMO S1/S1P

EVOLUTION



CASTAÑO VELCRO S2/S3

EVOLUTION

- Zapatos airflex -



NEXT AIR S201

92584 > S3+CI+HI+SRC > EN ISO 20345



NEXT AIR B201

92586 > S1+P+CI+HI+SRC > EN ISO 20345



NEXT AIR S101

92587 > S1+P+CI+HI+SRC > EN ISO 20345



NEXT AIR S501

92589 > S3+CI+HI+SRC > EN ISO 20345

- Bota de soldador -



ROBLE S2/S3

EVOLUTION



ROBLE VELCRO S2/S3

EVOLUTION

- Guantes -



621



921 Neopreno



611 N



322



DM3



258



254



440 DPP



401 SMC



404 X



405 B



404 ARPC



115151



440DP



5140



PU1400



5115



406VRW



416



418



570



576



580NR



PP2328

- Ropa -



- Epis -



- Ventiladores -



- Bombas horizontales -



- Bombas verticales -



- Bombas sumergibles -



- Bombas -

SAER
ELETTROPOMPE



SHURflo



furio
suministros industriales

- Bombas -



- Motores eléctricos -

ALren 
AUTO RENDIMIENTO



SIEMENS



ABB



furio
suministros industriales

- Motores eléctricos -



- Motores freno y embragues -

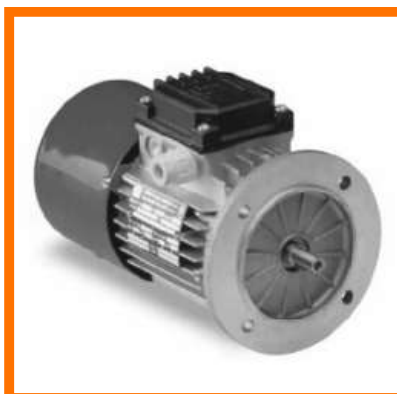
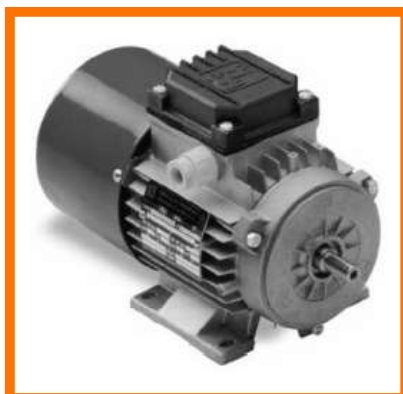

- Reductores -



- Reductores -



- Reductores -

TIMSA



cidepa
A GEARS BOXES COMPANY



- Reductores -



- Reductores -



- Reductores -

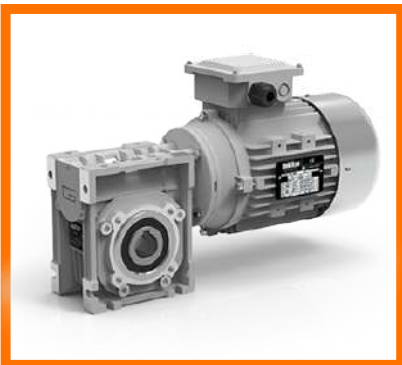

- Vibradores neumáticos y eléctricos -



- Freno-tambor neumático -

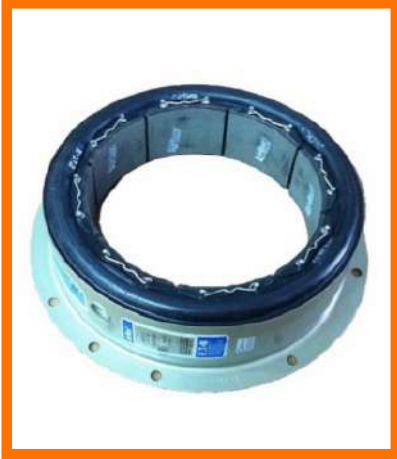

DUERRE

- Máquina Duerre y accesorios -

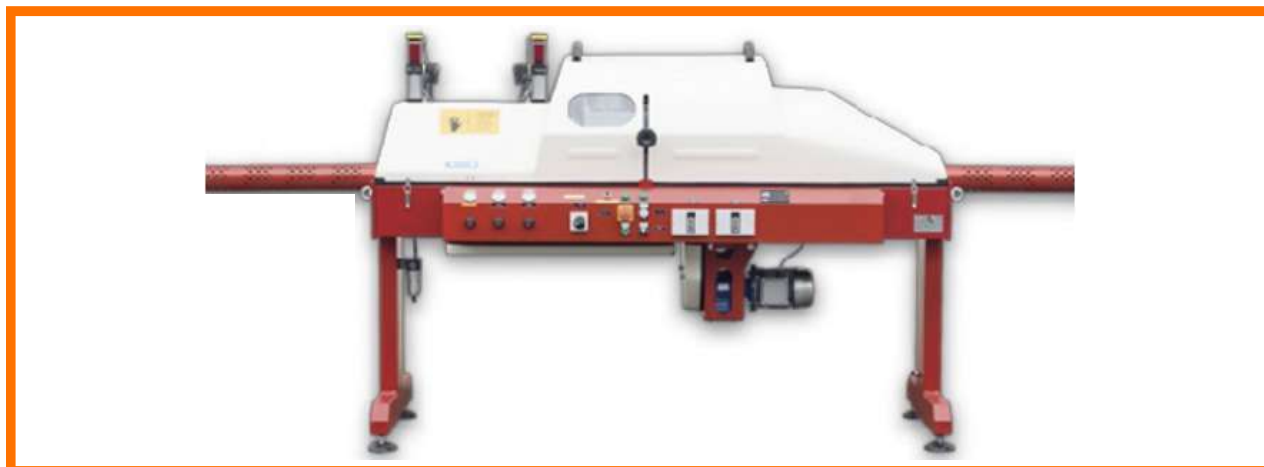

- Material horno -



SETER[®]

- Termocopias -

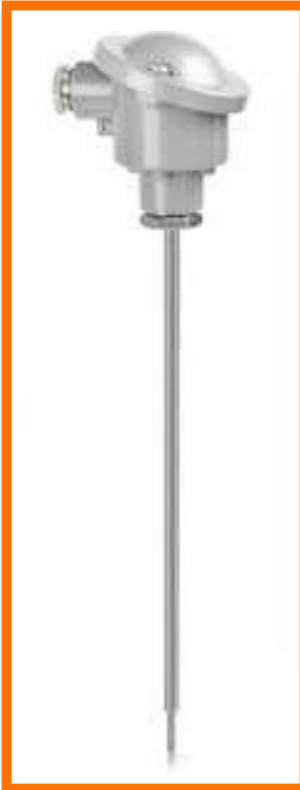

- Uñas rodamientos cerámicos -



- Muelles rodamientos cerámicos -



- Rodamientos horno -



- Repuestos de rectificadora y pulidora -



TIENNEKAPPA



- Correa Taracx para rectificadora -



REFERENCIA	DESCRIPCIÓN
CGF0076	CORREA FLEX 48 AT20 12000 + TARACX NARANJA 6 MM
CGF0128	CORREA FLEX 60 AT20 14000 + TARACX VERDE 3 MM
CGF0121	CORREA FLEX 73 AT20 14000 + TARACX VERDE 3 MM
CGF0047	CORREA FLEX 48 AT20 9560 + TARACX NARANJA 6 MM
CGF0055	CORREA FLEX 60 AT20 1136 + TARACX 3 MM
CGF0037	CORREA FLEX 73 AT20 1136 + TARACX 3 MM
CGF0142	CORREA FLEX 40 AT20 12800 + TARACX NARANJA 6 MM
CGF0141	CORREA FLEX 50 AT20 14380 + TARACX 3 MM
CGF0140	CORREA FLEX 50 AT20 12800 + TARACX NARANJA 6 MM
CGF0139	CORREA FLEX 80 AT20 14380 + TARACX 3 MM
CGF0024	CORREA FLEX 48 AT20 9560 + LINATEX NARANJA 6 MM
CGF0031	CORREA FLEX 73 AT20 11360 + PUR 2 MM
CGF0032	CORREA FLEX 60 AT20 11360 + PUR 2 MM
CGF0019	CORREA FLEX 75 AT20 9120 + PUR 2 MM
CGF0100	CORREA FLEX 75 AT20 10520 + PUR 2 MM
CGF0143	CORREA FLEX 40 AT20 11400 + TARACX NARANJA 6 MM
CGF0163	CORREA FLEX 50 AT20 12940 + PUR 2 MM
CGF0046	CORREA FLEX 50 AT20 9160 + TARACX NARANJA 6 MM
CGF0046	CORREA FLEX 75 AT20 10560 + PUR 2 MM

- Correa Fishbone PU para girador de rectificadora -



DESCRIPCIÓN	IMAGEN	MATERIAL	COLOR	DUREZA	ESPESOR	Tª MÁXIMA
PUR85		Poliuretano	Transparente	70	4 mm	70 °C
REFERENCIA	DESCRIPCIÓN					
065AT100256032 + FISH	CORREA PU 2560 AT10 L32 + NFT + FISHBONE PU + PAZ					
065AT100311032 + FISH	CORREA PU 3110 AT10 L32 + NFT + FISHBONE PU + PAZ					
065AT100336032 + FISH	CORREA PU 3360 AT10 L32 + NFT + FISHBONE PU + PAZ					
065AT100356032 + FISH	CORREA PU 3560 AT10 L32 + NFT + FISHBONE PU + PAZ					
065AT100376032 + FISH	CORREA PU 3760 AT10 L32 + NFT + FISHBONE PU + PAZ					

TIENNEKAPPA

- Mesas calibradoras -



- Green Tornado -



- Útiles diamantados / fickert -



- Útiles diamantados / fickert -



- Utensilios para máquina de corte -

Platos, distancias, canutos y tubo flexible

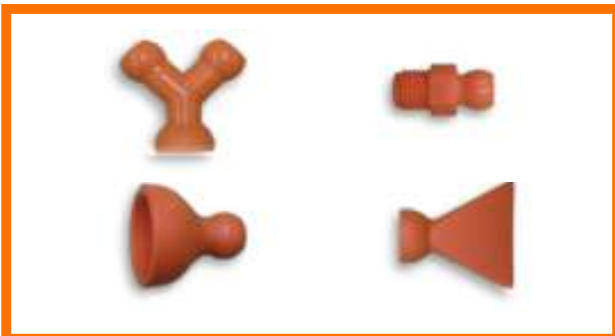

- Utensilios para máquina de corte -

Presores, barras y banda

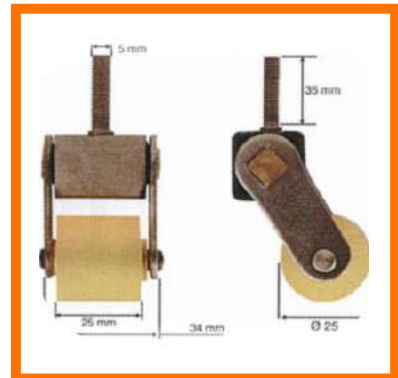
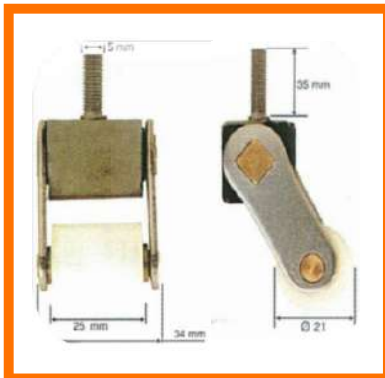
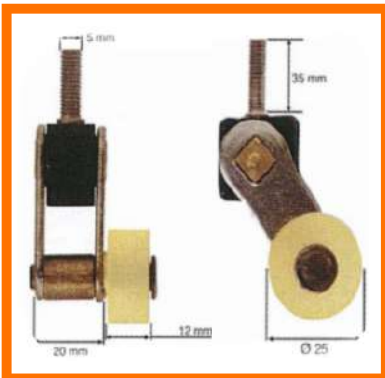
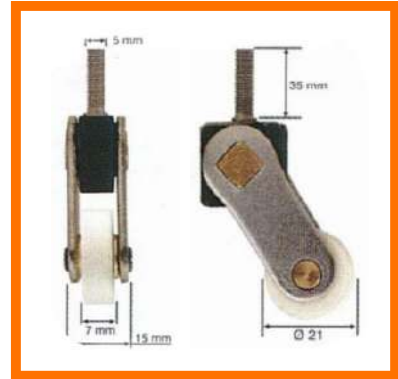
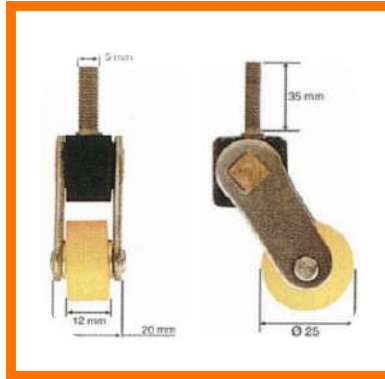
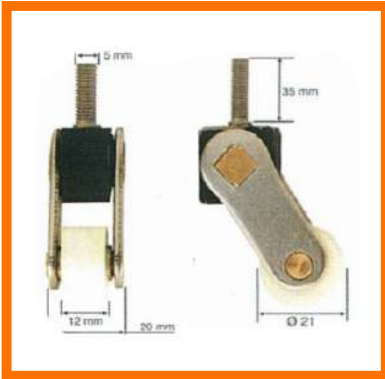

- Material atomizador -



- Material atomizador -

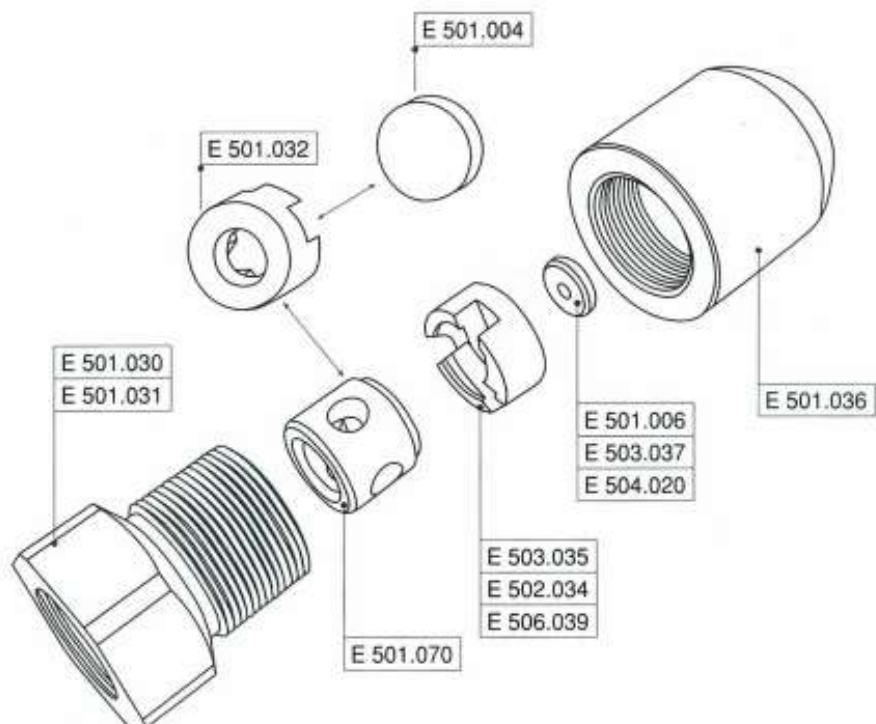

E501.030	Contenedor rosca 3/8 gas
E501.031	Contenedor rosca 3/4 gas
E501.070	Difusor integral
E501.032	Distribuidor
E501.004	Pastilla 19 ciega
E501.006	Pastilla agujereada diámetro 19, diámetro interior de 1 hasta 5,5 mm
E503.035	Caracola cónica 3 vías con asiento 14/19 altura h=8-9-10-11-13-15 mm
E502.034	Caracola cilíndrica 3 vías con asiento 19/19 altura h=8-9-10-11-13-15 mm
E506.039	Caracola cónica 3 vías con asiento 19/19 altura h=7-8-9-10-11-13 mm
E503.037	Pastilla agujereada 14 mm diámetro interior de 1 hasta 5,5 mm
E504.020	Pastilla agujereada diamantada diámetro 14, diámetro interior de 1 hasta 4 mm
E501.036	Cabeza e500

- Material atomizador -

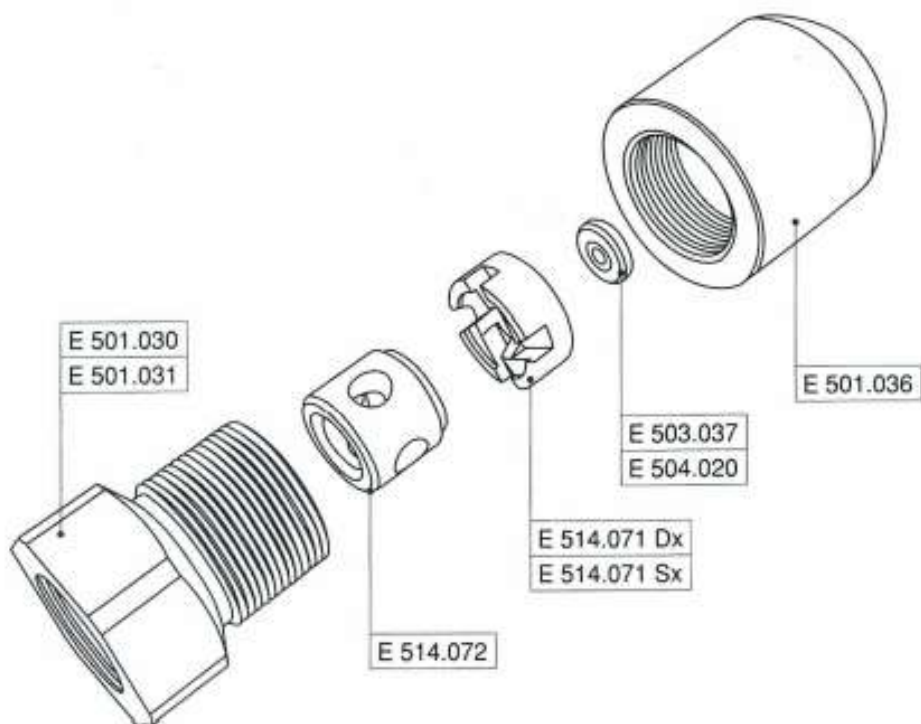

E501.030	Contenedor rosca 3/8 gas
E501.031	Contenedor rosca 3/4 gas
E501.072	Difusor integral 4w
E514.071D	Caracola cónica 4 vías derecha con asiento 14/19mm altura h=8-9-10-11-13-15 mm
E514.071S	Caracola cónica 4 vías izquierda con asiento 14/19mm altura h=8-9-10-11-13-15 mm
E503.037	Pastilla agujereada 14 diámetro interior de 1 hasta 5,5 mm
E504.020	Pastilla agujereada diamantada 14 diámetro interior de 1 hasta 4 mm
E501.036	Cabeza e500

- Material atomizador -

Modelo E3

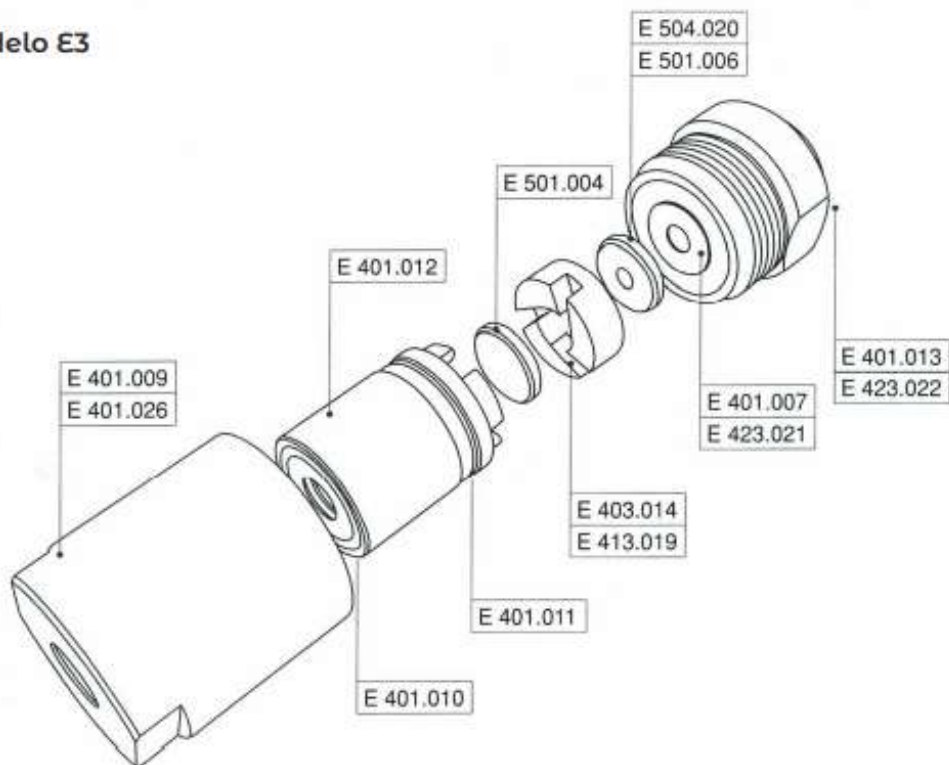

E401.009	Contenedor rosca 3/8
E401.026	Contenedor mod. e3 con rosca 3/4 gas
E401.010	Junta OR 25
E401.011	Junta OR 30
E401.012	Distribuidor
E501.004	Pastilla 19 ciega
E501.006	Pastilla agujereada 19 diámetro interior de 1 hasta 5,5 mm
E403.014	Caracola cilíndrica 3 vías altura h=6-7-8-9-10-12 mm
E413.019	Caracola cónica 3 vías altura h=5-6-7-8-9-10 mm
E401.013	Cabeza e3 para pastilla diámetro exterior 19 mm
E423.022	Cabeza e3 para pastilla diámetro exterior 14 mm
E423.021	Arandela bronce para pastilla diámetro exterior 14 mm
E401.007	Arandela bronce para pastilla diámetro exterior 19 mm
E504.020	Pastilla agujereada diamantada 14 diámetro interior de 1 hasta 4 mm

- Material atomizador -

Modelo MF

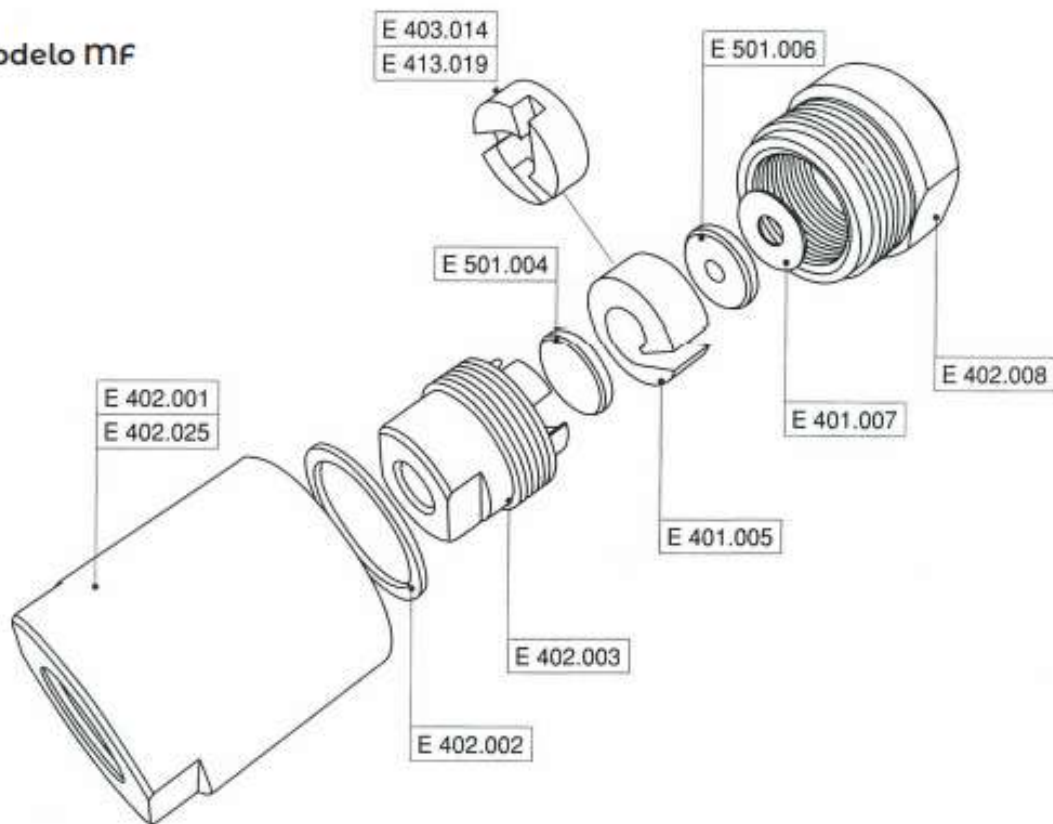

E402.001	Contenedor rosca 3/4 gas
E402.025	Contenedor rosca 3/8 gas
E402.002	Arandela de aluminio
E402.003	Distribuidor tratado negro
E501.004	Pastilla 19 ciega
E401.005	Caracola 1 vía altura desde 2 hasta 12 mm
E403.014	Caracola cilíndrica 3 vías altura h=6-7-8-9-10-12 mm
E413.019	Caracola cónica 3 vías altura h=6-7-8-9-10-12 mm
E501.006	Pastilla agujereada 19 diámetro interior de 1 hasta 5,5 mm
E401.007	Arandela bronce para pastilla diámetro exterior 19 mm
E402.008	Cabeza mf tratada

- Material atomizador -

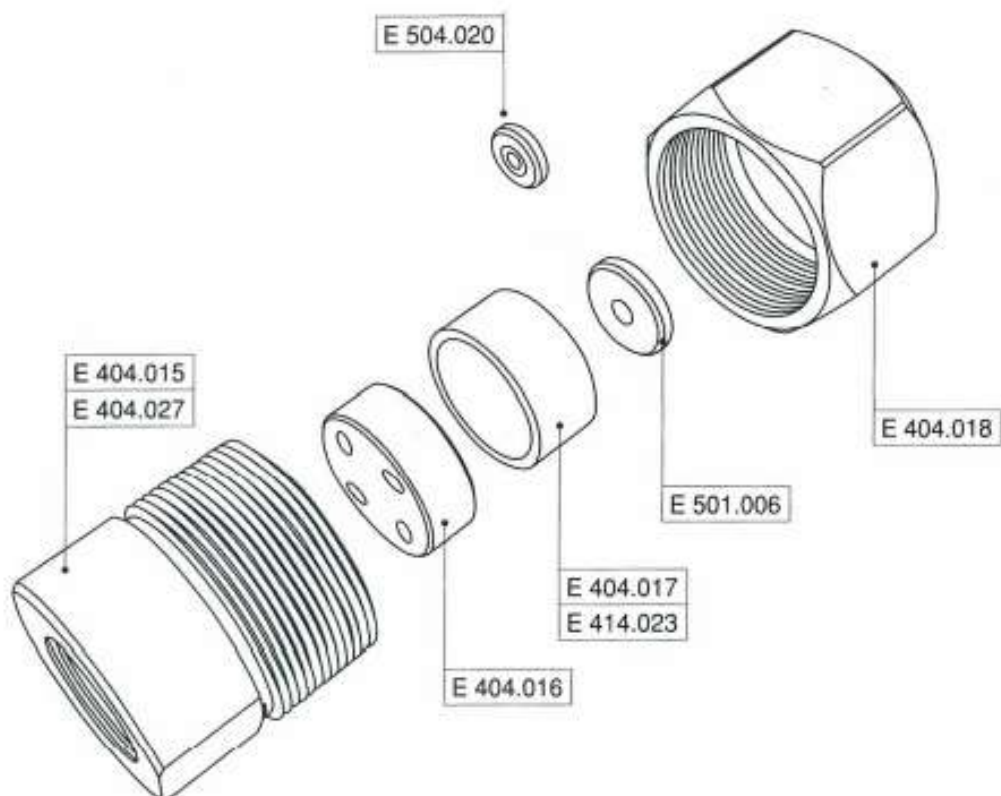

E404.015	Contenedor e4 rosca 3/4 gas
E404.027	Contenedor e4 rosca 3/8 gas
E404.016	Caracola 4 vías altura h=4-6-7-8-10-12 mm
E404.017	Reducción cónica e4 asiento 19
E414.023	Reducción cónica e4 asiento 14
E501.006	Pastilla agujereada 19 diámetro interior de 1 hasta 5,5 mm
E504.020	Pastilla agujereada diamantada diámetro 14 diámetro interior de 1 hasta 4 mm
E404.018	Cabeza e4

- Material atomizador -

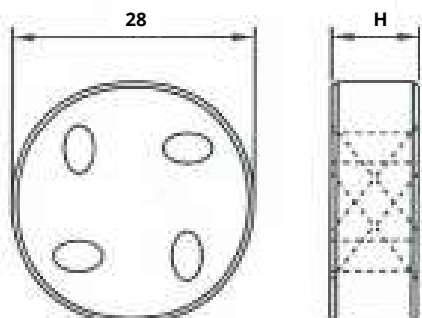

Cod. E 404.016

Caracola 4 vías

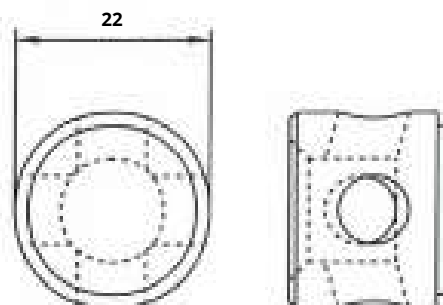

Cod. E 501.070

Difusor integral

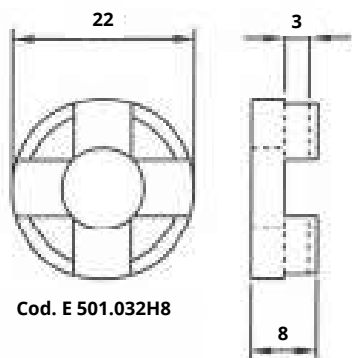

Cod. E 501.032H8

Distribuidor

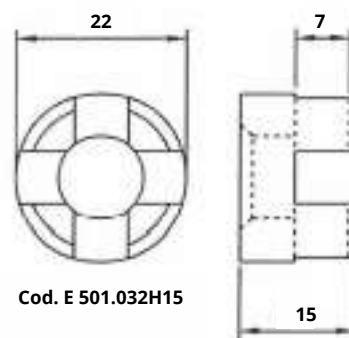

Cod. E 501.032H15

Distribuidor

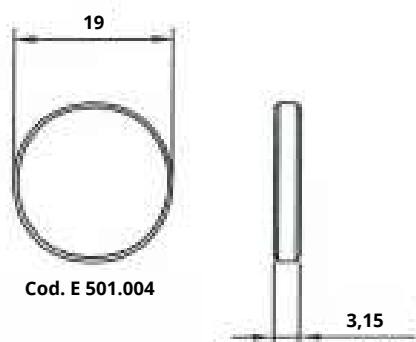

Cod. E 501.004

Pastilla ciega

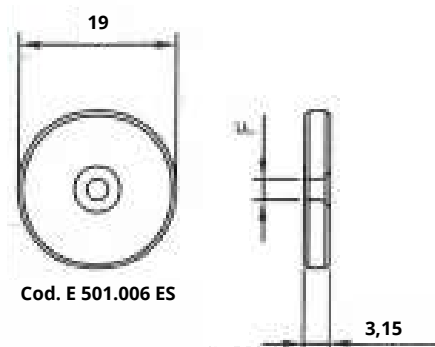

Cod. E 501.006 ES

Pastilla agujereada extra especial

- Material atomizador -

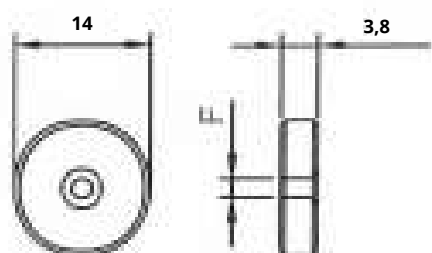

Cod. E 503.037

Pastilla agujereada

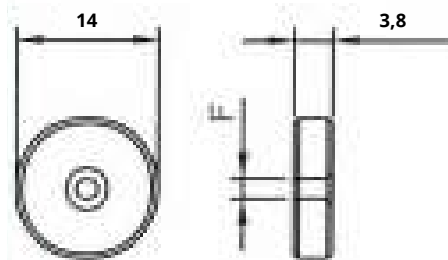

Cod. E 503.037 ES

Pastilla agujereada extra especial

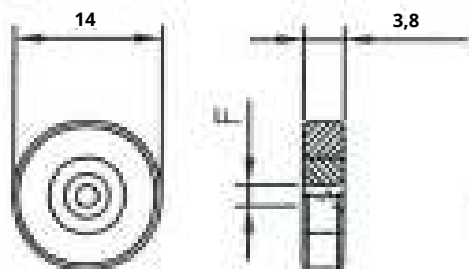

Cod. E 504.020

Pastilla agujereada diamantada

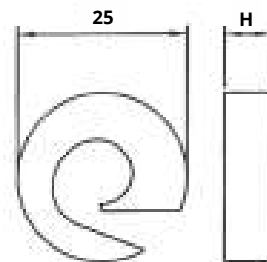

Cod. E 401.005

Caracola 1 vía

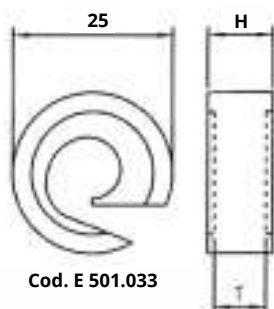

Cod. E 501.033

Caracola 1 vía con asiento 19/19

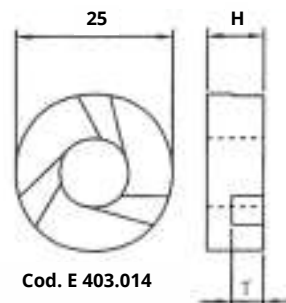

Cod. E 403.014

Caracola cilíndrica 3 vías

- Material atomizador -

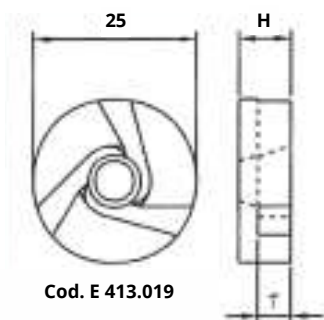

Cod. E 413.019

Caracola cónica 3 vías

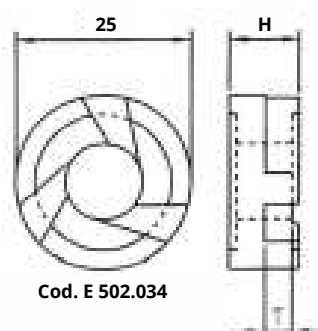

Cod. E 502.034

Caracola cilíndrica 3 vías con asiento para pastilla 19/19

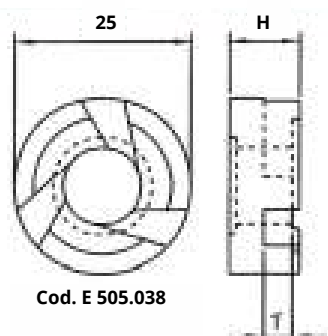

Cod. E 505.038

Caracola cilíndrica 3 vías con asiento 14/19

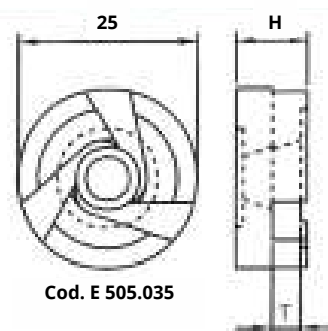

Cod. E 505.035

Caracola cónica 3 vías con asiento 14/19

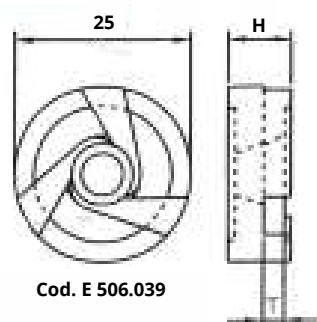

Cod. E 506.039

Caracola cónica 3 vías con asiento 19/19

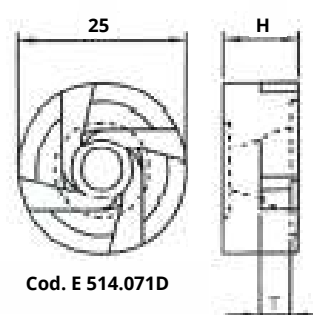

Cod. E 514.071D

Caracola cónica 4 vías con asiento 14/19

- Material atomizador -

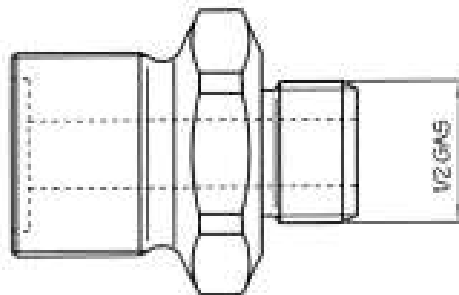

Contenedor rosca 1/2 gas

Cod. E 501.040

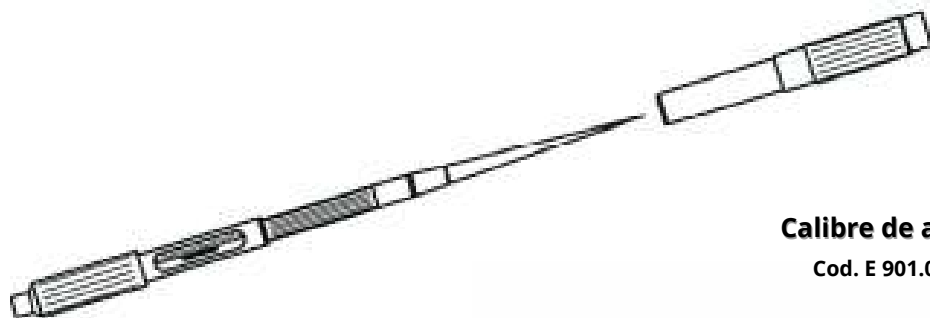

Calibre de aguja

Cod. E 901.001

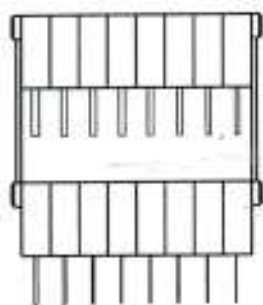

Calibre galgas para interiores

Cod. E 901.002

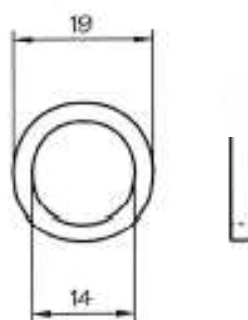

Anillo adaptador para pastilla 14

Cod. E 401.030

- Equipos de engrase para molinos continuos -



Cód. 5015019
Motobomba completa LD



Progresivo 8S-8D-8C-8CTD



Cód. 7050014
Limitadora



Cód. 5057004
Inversor



Cód. 7234005
Pistón



Cód. 6072702
PMF Elemento 08
con micro y conector



Cód. 6072709
PMF Elemento 65
con micro y conector



Cód. 9950-D1
Bomba Ram
Bidón 180 kg

Contacta con nosotros



964 91 30 80



info@suministrosfurio.es

Contacta con tu comercial



Jose Furio 649 87 07 84



Antonio Furio 670 90 65 80



Silvia Lacruz 637 27 72 02



Rosa Bayo 670 90 65 91

Visítanos

 Avenida Mediterráneo, 30. Onda (Castellón)

Síguenos en redes sociales



@suministrosindustrialesfurio



@suministrosfurio



suministros-industriales-furio



www.suministrosfurio.es



Avda. del Mediterráneo, nº 30
12200 Onda (Castellón)
Tel. 964 91 30 80 - Fax 964 91 05 03